

USER MANUAL

TERRAIN

DX4 · PRO · CAB · CLIMA

DX2

CORVUS



CORVUS INNOVA, limited company (CORVUS).

CORVUS OFF-ROAD VEHICLES® is a part of a registered trademark owned by CORVUS.

We reserve all commercial rights and/or the right to exploit the brand.

As CORVUS is constantly seeking new ways to improve the specifications, design and quality of its utility vehicles, ongoing modifications may take place. That is why the information in this catalogue may have changed since the time of printing. CORVUS reserves the right to modify models, colours, and/or technical specifications without notice and without incurring any obligation.

Drivers of CORVUS vehicles must comply with all requirements demanded by current legislation in relation to driving licenses and security measures required for the proper use of such vehicles. Never attempts stunts and avoid excessive speeds and abrupt turns. Never drive under the influence of alcohol or drugs.



USER MANUAL
CRVS-UM-20-EN-TER-123-1

CONTENT

General information	5	Trailer	22	Front hood base	55
Introduction	6	Side pods	23	Lights	56
Legal notices	6	Interior pods	23	Front low and high beam lights and indicators	57
Cautions and warnings	6	Specifications	24	Rear indicator, brake and sidelight lamp	58
Preliminary warnings	7	Multifunction panel	26	Liquid coolant	59
Vehicle identification	8			Radiator hosepipe and connections	60
Exterior components	9	Usage information	32	Hand brake cable	60
Driving seat	10	Break-in stage	33	Brake wear	61
Location of components	11	Daily inspection before driving	33	Brake fluid	61
Ignition key	11	Start-up process	37	Tires	62
Anti-theft lock key	11	Use of the rear differential lock	38	Bolts, nuts and fastenings	62
Front luggage compartment key	11	Use of 2wd/4wd transmission	39	Battery	62
Fuel tank cap key	11	Driving tips	39	Lighting and pilot lights	63
Pod key	11	Cleaning	41	Windscreen	64
Light switch	12	Storage	41	Fuses	65
Windshield wiper / washer button	12			Lubrication	67
Instrument panel	13	Maintenance	42		
Gearshift lever	13	Safety regulations et Maintenance standards	43	Product liability	68
2WD / 4WD transmission switch	14	Maintenance table	44		
Rear differential lock switch	14	Raising the vehicle	46	Warranty manual	70
Parking brake	15	Underbody protector	47	Preliminary warnings	71
Fuel tank cap	15	Wheels	47	Change of owner	74
Rear-view mirrors	16	Air cleaner	48		
Safety belts	16	Engine oil	49	Maintenance log	76
Seats	17	Water pre-filter	51		
Luggage compartment hood	18	Fuel filter	51		
Cargo box	19	Transmission oil	52		
		Front differential oil	53		
		4x4 locking system oil	54		



GENERAL INFORMATION

INTRODUCTION

We are delighted to be able to congratulate you on the purchase of your **CORVUS** vehicle and we would like to thank you for the confidence you have placed in us.

You are now the owner of a modern multi-purpose work vehicle that you will offer much enjoyment if you care for it and maintain it adequately. Before you start it up for the first time, please read the instructions of use carefully to become familiar with the handling and the characteristics of your vehicle. Only in this way will you be able to understand how to best adapt your vehicle to your requirements and how to avoid accidents. For your safety we recommend that you use only spare parts and accessories authorized by **CORVUS**.

If you use any other products, **CORVUS** declines all liability for any damages that may arise from so doing. We recommend you follow the instructions on the driving-in period and maintenance intervals in order to prolong the life of your vehicle. For maintenance work, you should always consult an official **CORVUS** distributor or dealer.

Driving in the countryside is fascinating and we hope you will enjoy it to the full. Although **CORVUS** vehicles are environmentally friendly, environmental problems and conflict with other people may ensue in the countryside. Handling the vehicle in a responsible way ensures that these problems and conflicts do not arise. Be sure to use the vehicle within the bounds of the law, show that you are environmentally aware and respect the rights of others.

#ExploringYourWorld.

LEGAL NOTICES

In the interest of technical development, **CORVUS INNOVA S.L.** reserves the right to modify the construction, equipment and accessories of its vehicles without notice. Size, weight and power data should be understood with the respective tolerances. Depending on the volume of your **CORVUS** equipment and accessories, and on the versions that are approved in compliance with the different laws of each State, there may be variations with regard to descriptions and illustrations. The photographs in this manual may not therefore correspond to the model you have purchased. For this reason, no liability can be derived from any error, printing error or omission.

In the event of any discrepancy or question about the content of this manual, we recommend that you contact our After-sales Service.

CAUTIONS AND WARNINGS

YOU SHOULD READ THIS MANUAL CAREFULLY AND COMPLETELY BEFORE YOU ENJOY USING IT FOR THE FIRST TIME. IT CONTAINS INFORMATION AND SUGGESTIONS THAT WILL FACILITATE THE USE AND HANDLING OF THE VEHICLE.

PAY PARTICULAR ATTENTION TO THE FOLLOWING WARNINGS THAT CAN BE FOUND IN THE MANUAL:



WARNING. A warning concerning a hazard that can cause damage to the vehicle.



DANGER. A warning concerning a hazard that can lead to personal and/or serious injury and even death.

PRELIMINARY WARNINGS

WARNING

Take proper precautions while driving, especially in turning manoeuvres; driving on slopes or in areas with obstacles can cause a collision or make the vehicle overturn.

Only people who have a driving license should drive this vehicle. It is advisable that the driver and their companion should use a helmet and goggles when using the vehicle. Do not cause the vehicle to jump or flip, be aware of changes in the terrain on which you are going to drive. Check the possible obstacles that you want to clear, do not attempt to clear major obstacles, such as fallen trees, rocks, slopes, muddy areas, etc.

Take care in slippery areas, drive at low speed, watch out for any possible loss of grip, do not tackle steep slopes.

DANGER

You should not use the vehicle in a way that is not in line with the criteria and instructions contained in this manual or in a way that may cause damage to persons or things.

These are some examples of unsafe use and misuse:

- Driving with more than two people in the vehicle.
- Not keeping the entire body inside the cabin.
- Transporting people in the cargo box.
- Not complying with the instructions for use and maintenance set forth in this manual.
- Exceeding the cargo and towing limits.
- Driving on unstable or not consolidated ground.
- Driving on terrain with an inclination of more than 15%.
- Do not drive through flooded areas (the maximum

temporary wading depth is 40 cm).

- Using accessories, parts or equipment that are not authorised by **CORVUS**.

Adapt the speed of the vehicle to the terrain. When driving downhill, use the short LOW gear and keep the speed as low as possible, gently applying the brakes without locking the wheels. Under no circumstances should you perform manoeuvres with a slope / elevation or downward slope greater than 15%. If you need to tow your vehicle, make sure the towing vehicle has sufficient drag and braking capacity, use a tow bar or a sufficiently long cable and do not go any faster than 10 km/h.

All technical and mechanical repairs must be carried out by an authorised **CORVUS** garage.

Do not use the vehicle nor leave the engine running in enclosed premises if they are not sufficiently ventilated, a concentration of exhaust gas can cause death.

DANGER

The exhaust pipe and other elements reach high temperatures during use and take time to cool down after you turn off the engine. Avoid handling or touching any elements during this period.

DANGER

Avoid using loose clothing that could get caught up with parts of the vehicle or the environment. Although total security is impossible, the use of adequate equipment reduces the likelihood and/or severity of injuries.

VEHICLE IDENTIFICATION (CHASSIS - ENGINE)

Your **CORVUS TERRAIN DX4** has an identification that indicates the: manufacturer, type approval, VIN, mass of the vehicle, maximum mass per axle (A1-A2) and towable mass (depending on type of braking and towing).



CORVUS INNOVA, S.L.			
T1x*			
e13*167/2013*00205*0 ²			
VS9CTRDXxxxxxxxx*			
1.400 kg			
A-1: 650 kg			
A-2: 950 kg			
	T-1	T-2	T-3
B-1	450 kg	450 kg	450 kg
B-2	907 kg	907 kg	907 kg
B-3	-	-	-
B-4	-	-	-

* Subject to model, version and homologation.

Your **CORVUS TERRAIN DX4** has an engine identification that indicates the: manufacturer, model, engine capacity and serial number.

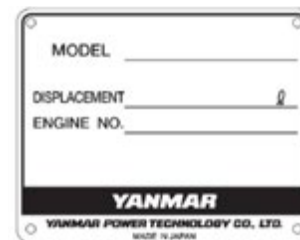
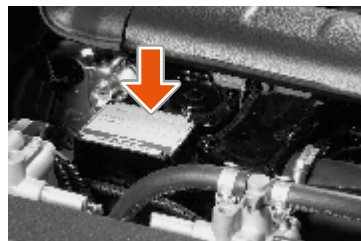

The **vehicle identification number** is also stamped on the rear right-hand side of the chassis.



EXTERIOR COMPONENTS

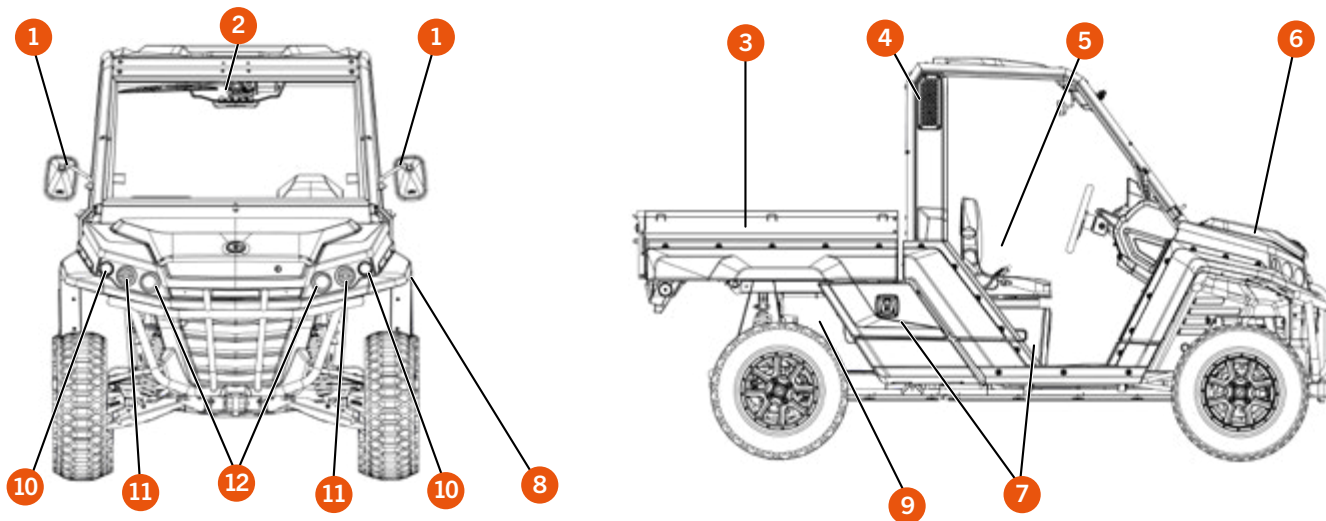

- | | |
|------------------------------------|-----------------------------|
| 1. Rear-view mirrors | 7. Side and interior pods* |
| 2. Windshield wiper* | 8. Fuel filler cap |
| 3. Cargo box | 9. Location of transmission |
| 4. Snorkel engine air intake / CVT | 10. Steering indicators |
| 5. Driving seat | 11. High beam |
| 6. Front hood | 12. Low beam (short) |

DRIVING SEAT

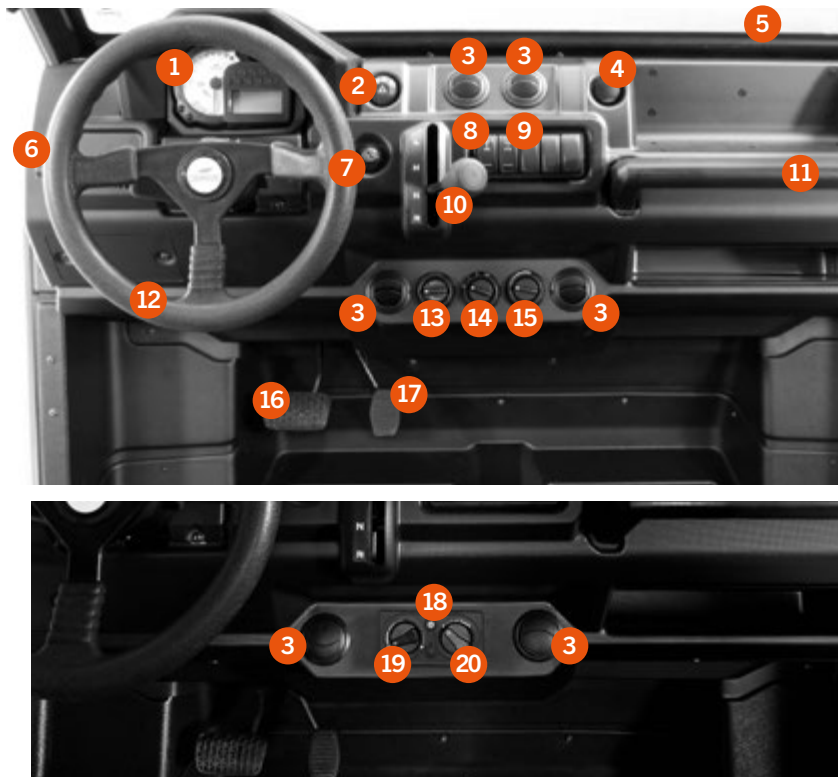

1. Instrument panel.
2. Emergency signal button.
3. Adjustable and sealable central air vents*.
4. 12V accessory socket.
5. Top air diffuser for windshield demisting*.
6. Lights control, steering indicators and horn.
7. Key start-up.
8. 4WD selector button.
9. Rear differential lock selector button.
10. Gear lever.
11. Co-pilot grip handle.
12. Steering wheel.
13. Air temperature selection control*.
14. Blower intensity control*.
15. Cold air selection control*.
16. Brake pedal.
17. Accelerator pedal.
18. A/C Switch*
19. Air temperature selection control*.
20. Blower intensity control*.

LOCATION OF COMPONENTS

IGNITION KEY (1)

The lock is located to the right of the steering wheel, has three positions:

- Off
- Contact
- Start-up

1



2



ANTI-THEFT LOCK KEY (2)*

The lock is located behind the steering wheel.

The lock has an engagement point as you turn the steering wheel travel and this is activated by turning the key on the steering wheel.

3



4



FRONT LUGGAGE COMPARTMENT KEY (3)

The lock is located at the front of the vehicle.

FUEL CAP KEY (4)

The fuel cap is located on the centre of the left-hand side of the vehicle.

POD KEY (5)*

The pods are located under the seats and on each side of the exterior of the vehicle.

5



LOCATION OF COMPONENTS

LIGHT SWITCH

Located to the left of the steering wheel, with the following functions:

-Activation of the horn

Push the lever toward the centre of the vehicle

-Flash function

Pull the lever toward the inside

-Long beam or road lights

Push the lever away from you

-Turn signal lamps

Move the lever upward (to turn right) and down (to turn left).

The side, dipped-beam or short lamps will turn on automatically when you connect the engine.



WINDSHIELD WIPER / WASHER BUTTON*

Located above the driving seat.

-WINDSHIELD WIPER

OFF Position- Lower position

ON Position - Central position

-WINDSHIELD WASHER

ON Position - Upper position



LOCATION OF COMPONENTS

INSTRUMENT PANEL

On the vehicle's instrument panel you can find:

1. Instruments.
2. Key start-up.
3. Emergency "Warning" flasher control.
4. Adjustable and sealable central air vents*.
5. Gearshift lever.
6. 4WD transmission switch.
7. Rear differential lock switch.



GEARSHIFT LEVER

The gearshift lever (1) is located in the centre of the instrument panel.

It has 4 positions:

- (L) - **LOW**: "Short-gear" forward.
- (H) - **HIGH**: "Long-gear" forward.
- (N) - **NEUTRAL**: Neutral.
- (R) - **REVERSE**: Reverse.

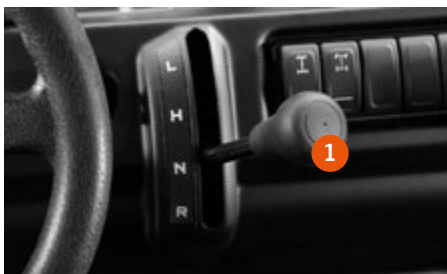

Do not shift to reverse gear if the vehicle is not completely stopped, as this may cause accelerated deterioration of the gearbox or even breakage.

Do not force the lever if the gear does not engage, accelerate softly and try to shift the gear again.

LOCATION OF COMPONENTS

2WD / 4WD TRANSMISSION SWITCH

Located in the centre of the instrument panel.

It has 2 positions:

2WD: 2 wheel drive -rear wheels- (1).

4WD: 4 wheel drive (2).



REAR DIFFERENTIAL LOCK SWITCH

Located in the centre of the instrument panel.

It has 2 positions:

OFF: Rear differential unlocked (1).

LOCK: Rear differential locked (2).



! It is recommended to activate the 4x4 and the differential lock when the vehicle is completely stopped in order to minimize the wear of the components.
NEVER engage the 4WD and differential lock when the steering is turned. Do not use the 4x4 and lock on paved roads.

Remember to proceed with the 4x4 actuator and gearbox services as indicated in the Maintenance Table (p. 44/45), to avoid premature deterioration.

LOCATION OF COMPONENTS

PARKING BRAKE

The parking brake is engaged by means of a lever located on the left-hand side of the driver seat.

It has 2 positions:

ON: Engage the parking brake by pulling the lever up firmly.

OFF: Lift the lever up slightly, push on the lock button and pull it down.

⚠ NEVER activate the parking brake while the vehicle is in motion, as this could cause an accident.



The audible warning will be activated in the following situations:

-When the vehicle does not detect presence in the driver's seat and the parking brake is not engaged.

-When any gear other than neutral (N) is engaged and the parking brake is on.

FUEL TANK CAP

The fuel tank filler cap is located on the left-hand side of the vehicle.

To open it you must use the specific key (4, p. 11).

- 1 - Insert the key into the lock.
- 2 - Turn the cap counterclockwise 1/4 turn.
- 3 - Remove the cap.

⚠ Continuous movement of the vehicle can produce gas in the tank. Open the cap slowly.

! Use diesel B7/B10, NEVER use any other fuel.



LOCATION OF COMPONENTS

REAR-VIEW MIRRORS

The vehicle has two rear view mirrors (1), one on each side, and a third one inside in the centre* (2).

 Adjust the rear view mirrors before driving to ensure maximum visibility.

 Do not manipulate the mirrors while driving.



SAFETY BELTS

The safety belts are 2-point and incorporate a cam to release them.

 Adjust the seat belts before driving to ensure maximum safety in the event of an accident.

 Always drive with seat belts properly fastened.
Do not adjust seat belts while driving.



LOCATION OF COMPONENTS

SEATS

3 adjustment points allow you to adjust the position of your seats so you can find your proper posture:

1. LONGITUDINAL POSITION:

Adjust the position by pulling the lever and moving the seat forward or backward. In the case of the driver seat, adjust the position so that you can press the pedals with your legs slightly bent.

2. BACKREST INCLINATION:

Use the handle to adjust the inclination of the backrest. In the case of the driver seat, until you can reach the highest point of the steering wheel with your arms slightly bent.

3. LUMBAR ADJUSTMENT:

Adjust the pressure in the lumbar region using the wheel on the side. Turn it forward for more pressure and backward for less.



Adjust the driver's seat position when the vehicle is completely stopped.

Adjust the seat so that your feet are completely flat on the floor and you can comfortably reach the pedals.

Do not manipulate the audible warning wiring, since it could break the electrical installation.



Do not introduce the hand in the longitudinal position mechanism as it could get trapped.



LOCATION OF COMPONENTS

LUGGAGE COMPARTMENT HOOD

To **open** the hood of the vehicle, you must use the special key (3, p. 11).

- 1 - Insert the key into the lock (1).
- 2 - Turn the key counterclockwise 1/4 turn.
- 3 - The hood will rise a few cm.
- 4 - Tilt the hood backward as far as it can go.

To **close** the hood of the vehicle,

- 1 - Lower the hood (2) slowly, without closing it.
- 2 - Press with both hands to anchor it.
- 3 - Remove the key from the lock (1).



When closing the hood, do not let it drop. This could cause injury to you or others.

Before driving off make sure it is completely closed.



Do not store flammable materials inside any of the compartments. Do not drive with trunk opened.



LOCATION OF COMPONENTS

CARGO BOX

The cargo box has a rear door (1) for easier loading and unloading of materials.

Opening the rear door

- The door has two side bayonet levers (2).
- Grasp the door by the centre and open the two bayonet levers, one after the other.



Avoid opening the two bayonet levers at the same time as this could cause leg injuries.

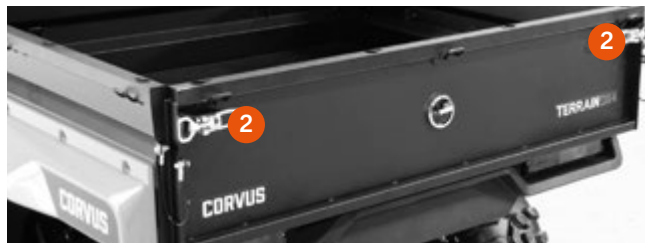

LOCATION OF COMPONENTS

Inclination of the box

To tilt the cargo box, proceed as follows:

- 1 - Turn the lever (1) clockwise.
- 2 - The box will be unhooked.
- 3 - Tilt the box up.

The box has two shock absorbers (2) that make it easy to tilt it and prevent recoil.



-An overload (max. 450 Kg.) can cause vehicle instability and may cause an accident.

- Place the load as far forward as possible.
- Place a net or tarpaulin over light or volatile loads.
- Use straps to secure the load to prevent it from moving in the cargo box.
- The box has interior hooks (3) for fastening purposes.
- If driving on uneven or unstable terrain, reduce speed to avoid movements that may make you lose control.
- Do not allow the load to protrude over the sides of the cargo box.
- Remember that the heavier the load, the longer it will take to stop the vehicle.
- Control the loading of fluid tanks and their internal displacements.



NEVER drive with a passenger in the cargo box.

Do not lift the cargo box when loaded. Doing so could pose a risk to the operator or even cause the vehicle to overturn. First unload the heavy load through the tailgate.

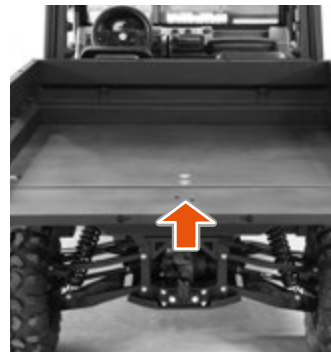

LOCATION OF COMPONENTS

Cargo box unloading:

To unload the cargo box safely, it is necessary to follow the following procedure:

1. Park the vehicle on a flat and level surface and activate the parking brake.
2. Open the tailgate and unload all or most of the cargo. Only lift the cargo box if you are absolutely sure it can be lifted. Do not lift with load.
3. Once it is unloaded, lower cargo box and fix it in.



NEVER LIFT THE CARGO BOX FULLY LOADED. DOING SO COULD CAUSE AN UNEXPECTED OR AGGRESSIVE LIFTING, WHICH WOULD BREAK THE SPRINGS AND COULD CAUSE SERIOUS INJURY TO THE OPERATOR.

ALWAYS UNLOAD THE VEHICLE ON A FLAT AND LEVEL SURFACE AND ACTIVATE THE PARKING BRAKE, TO AVOID THE VEHICLE TO OVERTURN.

NEVER DRIVE THE VEHICLE WITH THE CARGO BOX LIFTED OR THE TAILGATE OPENED.

PLACE A NET OR TARPULIN OVER LIGHT OR VOLATILE LOADS. USE STRAPS TO SECURE THE LOAD TO PREVENT IT FROM MOVING IN THE CARGO BOX.

DO NOT ALLOW THE LOAD TO PROTRUDE OVER THE SIDES OF THE CARGO BOX.

REMEMBER THAT THE HEAVIER THE LOAD, THE LONGER IT WILL TAKE TO STOP THE VEHICLE.

CONTROL THE LOADING OF FLUID TANKS AND THEIR INTERNAL DISPLACEMENTS.

NEVER DRIVE WITH PEOPLE ON THE CARGO BOX. THIS COULD CAUSE SERIOUS INJURIES TO THE PERSON, EVEN DEATH. IT IS ONLY ALLOWED TO TAKE PASSENGERS ON THE PASSENGER'S SEAT.

DO NOT PLACE HEAVY LOADS ON THE TAILGATE, AS IT COULD COLAPSE.

LOCATION OF COMPONENTS

TRAILER

The vehicle has a tow ball, located at the rear of the vehicle. It is important to know its load limitations. For this purpose there is an homologation plate that indicates the following information.

MODELO: CORVUS TERRAIN	
Maximum towing capacity for a trailer WITH inertia brake	907 kg
Maximum towing capacity for a trailer WITHOUT inertia brake	450 kg
Maximum vertical towball load	240 kg

 The vehicle can only tow more than 450kg if the trailer is equipped with an inertia brake. Always without exceeding the maximum load supported by the vehicle.

Do not pull or tow objects from any other point on the vehicle than the winch (if available) or from the hitches provided (one rear with tow ball and one front).

Never drive with passengers in the trailer.

The vehicle should be driven avoiding sharp turns or aggressive driving. Accelerate progressively and keep in mind that the braking distance will be affected by the trailer load.

 Do not exceed 16km/h when towing a load nor drive the vehicle with the short gear (L) engaged.

Do not drive on sloped or dangerous grounds when towing loads. If driving on difficult grounds is needed, reduce the speed significantly and constantly pay attention to elements that can be potentially dangerous for your safety.

When parking the vehicle with a trailer, it is important to do it on a horizontal surface. Do not park in slopes nor leave the vehicle with an engaged gear, as it will not prevent the vehicle from moving. Always use the parking brake.

In order to improve vehicle stability and to reduce the effects of towing a load, it is convenient to distribute the load weight between cargo box and trailer if possible.

Secure the load to the trailer correctly and make sure the space between the trailer and the vehicle is free from any elements that could damage any of them or affect driving.

In the upper part of the towing ball it can be found the 7-pin socket connector for towing. This socket has a maximum power of 150W, exceeding this power may result in serious damage in the electric system and must not be exceeded under any circumstance. This power will be reduced if there is something connected to any of the vehicle's auxiliary power points.

LOCATION OF COMPONENTS

SIDE PODS*

You will find a pod on each side of the TERRAIN:
You must use the specific key to open it (5, p. 11).

- 1 - Insert the key into the lock.
- 2 - Lift the handle.
- 3 - Turn the knob to the left or right.
- 4 - Slowly lower the cover.

To close it, carry out the same steps in reverse.

 The cover features a strap that prevent it from touching the ground.
Avoid placing weight on the cover.

 **NEVER drive the vehicle with compartments open.**
Do not drive the vehicle while drawers are being manipulated.
Do not place flammable materials in the compartments.

 Compartments are water resistant but not completely waterproof.
Do not place any object that can be damaged by humidity in them.





INSIDE PODS*

You will find three pods under the seats:
You must use the specific key to open it (5, p. 11).

- 1 - Insert the key into the lock.
- 2 - Lift the handle.
- 3 - Turn the knob to the left or right.
- 4 - Slowly lower the cover.

To close it, carry out the same steps in reverse.

 **NEVER drive the vehicle with compartments open.**
Do not drive the vehicle while drawers are being manipulated.
Do not place flammable materials in the compartments.

 Compartments are water resistant but not completely waterproof.
Do not place any object that can be damaged by humidity in them.



SPECIFICATIONS

ENGINE

Cycle	4 stroke
No. of cylinders	3 cylinders in line
Cooling	Liquid
Displacement	993 cc
Diameter / stroke	74 mm x 77 mm
Compression relay	23.54:1
Layout	OHV - 6 Valves
Start-up system	Electric (12V-1.2 KW)
Alternator	12V - 55A
Battery	12V / 55Ah
Max. torque (ISO Nm)	52.1 Nm at 2400 rpm
Maximum power	17.8 kw (23.87 hp) 3600 rpm
Maximum speed	T1a: H-40 Km/h / L-22 Km/h T1b: H-60 Km/h / L-33 Km/h

LIQUIDS

Fuel	Diesel B7 / B10
Coolant	50% ESPC. G12 Qty: 7 L
Brake fluid 1	DOT-4
Engine oil	SAE 15W40 - API CD, CF, CF-4 y CI-4. Qty: 1,7 L
Transmission oil	SAE 80W-90 GL5 EP Qty: 1,7 L
Differential oil	SAE 80W-90 GL5 EP Qty: 0,5 L.
WD actuator oil	SAE 80W Qty: 0,05 L

TRANSMISSION

Transmission	Automatic CVT		
Gearshift ratio	T1a	T1b	
	High	3,50	2,29
	Low	6,13	4
	Reverse	7,09	4,63
Gear ratio	3,33	2,99 - 0,61	
Transmission	4x4 / 2x4. Read diff. lock		

CABIN

Windshield	Front *	Fixed laminate
	Rear *	Fixed tempered
Seats	2, separated	
Windshield wiper *	Control unit	
Seat belt	2-point	

HOMOLOGATION

Type	EU T1a / T1b
Emission of gases	EC STAGE V (<19kW) EPA FINAL TIER 4 (<19kW)

1.- Cold weather countries should adjust the antifreeze to suit the temperature.

SPECIFICATIONS

DIMENSIONS

Total height	1.973 mm
Total length	3.414 mm
Total width	1.656 mm
Distance - axles	2.238 mm
Ground clearance	309 mm
Track width	
Front	1.396 mm
Rear	1.370 mm
Cargo box	
Length	1.202 mm
Width	1.340 mm
Height	300 mm
Volume	0,48 m3
Weight dry	764 kg
Weight with liquids	785 kg (10 L of fuel)
DX4 weight	799 kg
PRO weight	838 kg
CAB weight	892 kg
DX2 weight	757 kg
Payload capacity	630 kg
Fuel tank capacity	40 L
Load capac. rear box	450 kg
Towing capacity TEC	907 kg

CHASSIS

Type		Round tubular, spine-shaped steel chassis.
Suspension		
Front		Independent with Anti-Dive system with overlapping trapeziums. Gas shock absorbers with adjustable settings.
Travel		280 mm.
Rear		Independent with overlapping trapeziums. Gas shock absorbers with adjustable settings.
Travel		270 mm.
Brakes		Parallel double circuit per independent axle.
Disks		
Front		256 mm. with 2-piston callipers
Rear		220 mm. with 1-piston callipers
Parking		Mechanical callipers on the rear discs.
Steering *		Electric assisted rack with 2 turns between ends.

MULTIFUNCTION PANEL

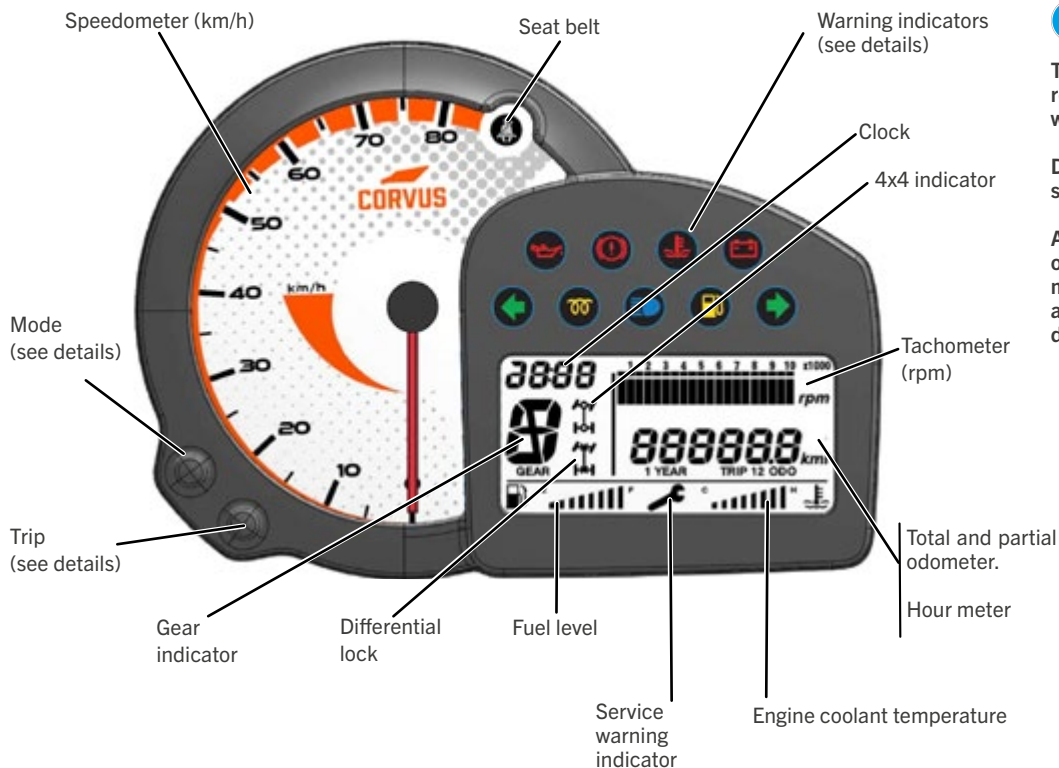

The multifunction device is water resistant but not waterproof. Do not wash it with water under pressure.

Do not leave the device in direct sunlight when the vehicle is not in use.

Avoid contact with petrol, degreasers or other chemical cleaners as they may damage the device. Remember to always pay attention to the road while driving.

MULTIFUNCTION PANEL

WARNING INDICATORS



Oil pressure

Warning indicator to show the correct oil pressure in the engine. The warning indicator will illuminate for a few seconds when you switch on the vehicle using the ignition key. Once the vehicle has started up, it will turn off. More information in the maintenance section of this manual. If the warning indicator illuminates when the engine has started or when you are driving, you must turn off the engine and contact your nearest CORVUS garage.



Parking brake and brake fluid level malfunction

Warning indicator to indicate that;

- The parking brake is activated;
- The driver is not seated in the seat;
- Or there is a malfunction in the braking system or a lack of brake fluid. If so, park the vehicle and contact your nearest CORVUS garage.

The warning indicator will illuminate for a few seconds when you switch on the vehicle using the ignition key. More information in the maintenance section of this manual.



Engine coolant temperature

Warning indicator to indicate the correct temperature of the coolant in the radiator. The warning indicator will illuminate for a few seconds when you switch on the vehicle using the ignition key. More information in the maintenance section of this manual. If the warning indicator illuminates when the engine has started or when you are driving, you must turn off the engine and contact your nearest CORVUS garage.



Battery level

Warning indicator to indicate the battery is charging correctly. The warning indicator will illuminate for a few seconds when you switch on the vehicle using the ignition key. More information in the maintenance section of this manual. If the warning indicator illuminates when the engine has started or when you are driving, you must turn off the engine and contact your nearest CORVUS garage.



Steering indicators

Warning indicator will illuminate when you use the lever or the emergency button to indicate a change of direction.



Diesel heaters

Warning indicator to indicate that the combustion chamber is warming up to make it easier to start the engine. Start the engine when the warning indicator has turned off. The warning indicator will illuminate for a few seconds when you switch on the vehicle using the ignition key. If the warning indicator illuminates when the engine has started or when you are driving, you must turn off the engine and contact your nearest CORVUS garage.



Long-range lights

Warning indicator to indicate that the long-range lights are switched on to enable greater visibility. Change to low beam when vehicles or people are in front of you.



Fuel level

Fuel tank capacity of 40 L. of diesel fuel, type B7 / B10. The warning indicator will illuminate when there are 5 litres of fuel left.

MULTIFUNCTION PANEL

FUNCTIONALITIES

Speedometer

- The dial of the speedometer has a linear scale of 0 to 80 km/h.
- The minimum speed displayed will be 3 km/h.

Odometer

- When the odometer is shown, it will display the ODO symbol.
- We can access TRIP-1 from the odometer by pressing "MODE" (<2 s).
- We can access the running hours from the odometer by pressing "TRIP" (>2 s).
- We can change the time from the odometer by pressing "MODE" (>2 s).

Hours of operation

- The indicator has 6 digits, including a decimal point indicating the number of 10-minute fractions that have elapsed. It also shows the letter "h" for the hours of operation.
- The counter only increases in value when the engine is started using the ignition key.
- We can access the odometer from the hour meter by pressing "TRIP" (>2 s).
- We can access TRIP-1 from the hour meter by pressing "MODE" (<2 s).
- We can change the time from the hour meter by pressing "MODE" (>2 s).

Trip-1 (partial counter 1)

- The indicator has 4 digits (with a decimal point) + the KM symbol.
- When the partial counter reaches 999.9 km, the counter returns to 0.
- Pressing on the SELECT button (for > 2 s) resets the counter to 0.
- When the partial counter is shown, the TRIP 1 symbol is shown.
- We can access TRIP-2 from TRIP-1 by pressing "MODE" (<2 s).

Trip-2 (Partial counter 2)

- The indicator has 4 digits (with a decimal point) + the KM symbol.
- When the partial counter reaches 999.9 km, the counter returns to 0.
- Pressing on the "TRIP" button (for >2 s) resets the counter to 0.
- When the partial counter is shown, the TRIP 2 symbol is shown.
- We can access the ODOMETER from TRIP-2 by pressing "MODE" (<2 s).

MULTIFUNCTION PANEL

MAINTENANCE SERVICE

- Maintenance intervals are indicated each 100 hs of operation, 1500 km or every year “1 YEAR”.

100 HOURS

- The hours will start at 100 and decrease until they reach 0.

- The hours remaining before maintenance is due will appear for 5 seconds when we put the key in.

- During these 5 seconds, pressing the button “TRIP” for less than two seconds will display the days remaining before the “1 Year” service is due, with a - symbol.

- During these 5 seconds, pressing the “MODE” button for less than two seconds will display the km that remain before a service is due or the km that have been exceeded.

- When the hours are equal to 100 hours, the service icon will remain on.

1500 KM

- When you have travelled 1300 km, the service symbol will flash on the screen.

- When you reach 1500 km, the service symbol will remain on.

- When the kilometres are displayed, if they have not already been exceeded, their number will come preceded by a - sign.

- If you have exceeded the kilometres by when the next inspection is due, when you turn the vehicle on the excess kilometres will be displayed on screen preceded by the letter E.

1 YEAR

If 1 year goes by before you have travelled the kilometres at which maintenance is due, the service symbol will activate with the text “1 Year”.

When there is one month left before the service is due, the service sign will flash with the “1 Year” symbol.

When the days of use are 365 or more, both icons will remain turned on.

To activate the icon for the “1 Year Service”, you must turn off the vehicle and when you turn it on again, the icon will appear.

The counter associated with maintenance-by-time will not activate until the vehicle has covered a distance of at least 10 km.

MAINTENANCE INTERVAL RESET

Resetting the service will establish the next revision at 100 hours, 1,500 km or 1 year without considering the values at the time the reset is performed.

Reset the service by switching the vehicle on and pressing “MODE” for 10 seconds (the service icon will flash) and then “TRIP” for 5 seconds. We have 10 seconds within which to press the “TRIP” button once the service icon flashes, before it times out.

You cannot be moving at any speed when performing the reset.

MULTIFUNCTION PANEL

24 h clock

The clock is displayed in the 24 h format (HH:MM + the Clock symbol) or Select the odometer function using the “MODE” button.

- Press the “MODE” button for more than 2 seconds (until the two hour digits flash).
- Repeatedly press the “TRIP” button to increase the digits of the hours.
- Keep pressing the “TRIP” button to increase the hours.
- Press the “MODE” button to accept the hours and change the field to the minute units.
- Repeatedly press the “TRIP” button to increase the minutes.
- Keep pressing “TRIP” to increase the minutes.
- Press the “MODE” button to accept the minutes and exit the clock setting function.
- If you do nothing for more than 10 seconds, and if you have not pressed any button, the clock setting function is exited automatically.
- If you have changed the hour or minutes, but you do not save them, the time-out will be 20 seconds.
- You can only change the time if the vehicle is completely stopped, without any speed pulses being received.

Gear

The gear will be indicated on the screen by an alphanumeric digit that can display:

- N to indicate that you are in NEUTRAL.
- R to indicate that you are in REVERSE GEAR.
- L to indicate that you are in SHORT GEAR.
- H to indicate that you are in LONG GEAR.

Revolution counter

The instrument displays the engine revolutions via a bar indicator.

It has a total of 10 bars that will serve to indicate the range of 0 to 5000 rpm (one bar is equivalent to 500 rpm).

MULTIFUNCTION PANEL

MODE - TRIP buttons

INDICATORS	PUSH-BUTTONS				NEXT STATE
	SHORT MODE	SHORT TRIP	LONG MODE	LONG TRIP	
ODO	X				TRIP 1
				X	Hours of operation
			X		Add time
HOURS OF OPERATION	X				TRIP 1
				X	ODO
TRIP 1	X				TRIP 2
				X	Reset TRIP 1
TRIP 2	X				ODO
				X	Reset TRIP 2
ADD TIME		X			Add time
	X				Increase minutes
ADD MINUTES		X			Increase minute
	X				Save time
SERVICE		X			"1 YEAR" service
	X				"Km" service



USAGE INFORMATION

BREAK-IN STAGE

It is **IMPORTANT** to respect the break-in stage which will ensure your engine's duration and correct functioning in the long term.

The following intervals should be respected:

- During the first 100 km, it is advised that you do not drive at maximum power.
- From 0 to 200 km: Drive at between 50% and 75% of engine load (throttle position), alternatively, without continued use of 75% of engine load.
- From 200 to 300 km: Drive in the same way but occasionally, albeit not for more than 5-10 seconds, at 100% of engine load.
- From 300 to 400 km: Drive at 75% to 100% of engine load, alternatively, without maintaining peak engine load.
- From 400 km on, increase gradually the demand during between 60 to 80 km, until you reach peak performance.

 **Reckless acceleration can cause problems in the engine. Take care that you use the skills and techniques needed to drive the vehicle.**

DAILY INSPECTION BEFORE DRIVING

 These checks can actually be performed very quickly, it is a question of habit. The user knows to what use the vehicle has been subjected the last time it was used and where to intensify this control. Respecting this set of controls implies greater security for the user and, undoubtedly, better and more economical maintenance of your vehicle.

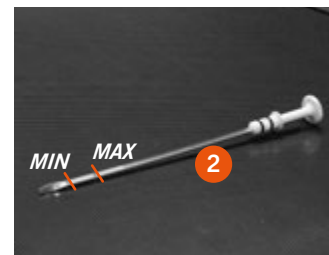

Before driving, have the vehicle on a level surface and perform the following checks:

Do you have enough fuel?

Check the current fuel level on your multifunction panel (1); try to fill the tank before each use.

Is the engine oil level correct?

Use the cap/dipstick (2) to check that the level is adequate and, if necessary, add oil.

DAILY INSPECTION BEFORE DRIVING

Is the coolant level correct?

You will find the coolant tank (1) inside the luggage compartment hood. The liquid must not exceed the MAX line; if necessary, add coolant.

⚠ Do not open the cap when the engine is warm, you run the risk of severe burns.

Recommended fluid: 50% long time (-35°).

Do not allow the coolant to fall on the skin or any surface. It can produce burns or corrosion. If coolant touches the skin clean with abundant water.

! If coolant level is correct and the vehicle temperature keeps increasing, even if its turned on for a few minutes, it can be due to the presence of bubbles in the circuit and must be purged. If high temperature persists please contact CORVUS service.



Is the brake fluid level correct?

It is located inside the luggage compartment hood. The container is translucent (1). Its level must be between MIN/MAX; if necessary, add brake fluid.

⚠ If the brake fluid level is under or over the limits shown on the tank, check the thickness of the brake pads and make sure they have not reached their usage limit. If the thickness is correct, fill up the brake fluid and make sure there are no leaks: if in doubt, go immediately to your CORVUS dealer, they know what to do in each case. This can affect your safety.

NEVER drive with low level of brake fluid. Check fluid level regularly and carry out maintenance as instructed in Maintenance Table (p. 44/45).

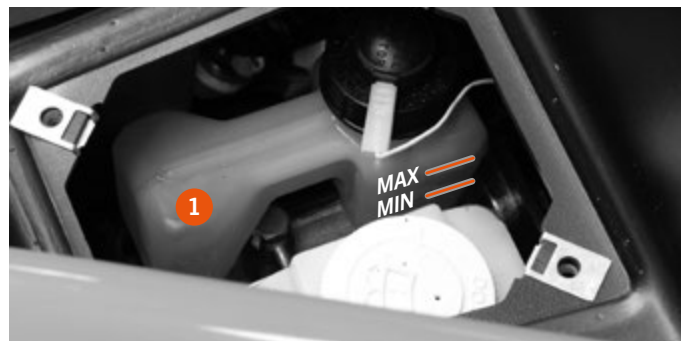

DAILY INSPECTION BEFORE DRIVING

Do the brake discs look okay?

Any important scratches, cracks, excessive wear, etc. can be easily spotted.

⚠️ Check that the thickness of the discs is at least 3.5 Mm at the front and 3.5 Mm at the rear.

Go immediately to your corvus dealer if you don't know what to do in each case. This can affect your safety. You should not drive the vehicle.

Are the front and rear brake pads in good condition?

Check the thickness of the remaining lining, ensuring that the thickness of the lining is not less than 1.5 mm. If it is, contact your CORVUS dealer to replace them.

⚠️ NEVER drive with worn brake pads. Pads in this state lose efficiency and may suppose a serious risk for your safety. Please attend your CORVUS service to change brake pads immediately.

Check that all controls feel the same to you.

The brake pedal, accelerator pedal, gearshift lever, 2WD/4WD transmission switch, hand brake lever, light panel, start-up system, horn and indicators. All these commands and control elements have their own characteristic functioning and touch, any change indicates an abnormality or damage. Nobody knows your vehicle better than you do, if you notice any changes, go immediately to your CORVUS dealer.



DAILY INSPECTION BEFORE DRIVING

Do the tires appear to have the correct pressure?

If in doubt, ALWAYS check the pressure level. If the problem persists, or is repeated, there may be a leak: see your CORVUS dealer.

Recommended front/rear pressure:

- 1.0 bar (empty vehicle)
- 1.5 bar (vehicle at full load)

Wear limit on tyre tread: 3.5 mm deep.

Is there the risk of any element falling off?

Fenders, side covers, tank, mud flaps, etc. If there is any such risk, you should try to attach it or remove it so that it does not fall off, for the sake of your safety. Visit your CORVUS dealer to have it repaired.

Are there any leaks?

Visually check for leaks, assessing them on the basis of their location, amount and the product that is leaking (be aware of the danger of fire). Always go as quickly as possible to your official CORVUS distributor or dealer.

Do the seat belts work properly?

The seat belt will not function properly if the buckle or the strap of the belt are dirty or damaged. For this reason, always keep the buckle and the strap of the safety belts clean, because otherwise, the tongue of the belt will not click into place correctly.

Regularly check the seat belts to ensure that:

- They are not damaged.
- They are not in contact with sharp edges.
- They are not entangled.

In case of doubt or anomaly, go to your CORVUS dealer.

Does the lighting and signalling system light up properly?

Regularly check all the bulbs of the lighting and signalling system are working properly. If you detect that any of them have burned out, replace them immediately.



Regularly review the tightening torque of the screws of the vehicle, paying special attention to the suspension, bushings, wheel spindles, transmission, steering and brakes.

NEVER drive without a screw or nut. Lighting and signaling systems are important security measures and vehicle should not be driven without any of them.

START-UP PROCESS

Follow these steps to start up your CORVUS:

1. Place the gearstick (1) in the N position (neutral).
2. Step on the brake pedal without stepping on the accelerator.
3. Turn the key (2) to the heater position and wait a few seconds in that position until the “diesel heaters” signal turns off.
4. Then turn the key (2) until the engine starts turning over.
5. Once you have started up the engine, let go of the ignition key.

NOTE:

Make sure that the engine maintains a minimum idling speed of 1.250 rpm.



The gearshift lever must be operated with the vehicle completely stopped and the engine running at the minimum possible level, without accelerating.

Failure to comply with this instruction can cause severe damage to the transmission.

Do not drive with the hand brake on.

Do not operate the hand brake to stop the vehicle. Doing so can cause serious damage to the braking system of the vehicle and can be dangerous. When moving into gear, accelerate gently, avoiding abrupt accelerations.



Before starting the engine, make sure the gearshift lever is in neutral. Do not accelerate.

Failure to comply with this instruction can cause severe damage to the transmission.



START-UP PROCESS

To **begin driving** with your CORVUS, follow these steps:

1. Step on the brake pedal, without stepping on the accelerator.
2. Put the gearshift lever in L, H or R, and choose the direction of travel.
3. Release the parking brake. Make sure that is completely disconnected.
4. Accelerate gently in the selected gear. When accelerating the vehicle, it is possible that on occasions it may not move and it may make a small metallic noise. This is due to the fact that the gear has not been fully engaged; in this case, stop accelerating and wait for the engine to return to idling speed, push the shift lever to select the gear ratio you want and accelerate gently at the same time, you will notice a “click” on the shift lever which confirms that the gear has been fully engaged. You can now release the gearshift lever and start moving.



USE OF THE REAR DIFFERENTIAL LOCK AND UNLOCK

 It is recommended to activate the rear differential lock with vehicle completely stopped to minimise worn in the components.

NEVER be used in roads.

Failure to comply with this instruction can cause severe damage to the engine.

To **lock the rear differential** perform the following steps:

1. Step on the brake pedal, without stepping on the accelerator.
2. Disconnect the hand brake. Make sure that is completely disconnected.
3. Put the gearshift lever into NEUTRAL (N) - central position.

To **unlock the rear differential** perform the following steps:

1. With the vehicle completely stopped, step on the brake pedal, without stepping on the accelerator.
2. Put the gearshift lever into NEUTRAL (N) - central position.

USE OF 2WD / 4WD TRANSMISSION*



It is recommended to activate the 4x4 with vehicle completely stopped to minimise worn in the components.

4wd and lock should never be used on the road or on paved areas.
4wd and lock can only be used up to 20 km/h.

Failure to comply with this instruction can cause severe damage to the engine.

To **ENABLE 4WD transmission** perform the following steps:

1. Step on the brake pedal, without stepping on the accelerator.
2. Put the gearshift lever into NEUTRAL (N) - central position.

To **DISABLE 4WD transmission** perform the following steps:

1. With the vehicle completely stopped, step on the brake pedal, without stepping on the accelerator.
2. Put the gearshift lever into NEUTRAL (N) - central position.

DRIVING TIPS

GENERAL INFORMATION

- Keep the entire body inside the vehicle while driving.
- Keep both hands on steering wheel while driving.
- Copilot's seat can be used by a passenger when vehicle is used.
- Make sure the passenger is correctly seated and has seat belt fastened.
- Be alert to possible dangers that may go into the vehicle.
- Abrupt or aggressive manoeuvres when driving, even in open spaces and flat surfaces, may cause control loss and possible overturns.

PRECAUTIONS IN TURNS

- Abrupt turns in the steering wheel at a significant speed may cause overturns.
- Avoid driving with the vehicle laterally inclined and if needed please turn gradually.
- Slow down before turning and avoid sudden brakings while turning.
- If you need to make turns with the vehicle completely stopped or at a low speed please accelerate progressively.

DRIVING ON SLOPES OR HILLS

- Try not to go across hills. If unavoidable, drive slowly and go down the hill if you feel the vehicle may overturn.
- Slopes with high inclination can cause overturn.
- Drive slowly at a constant speed. If vehicle stops moving forward brake progressively until stopped. Engage reverse and let the vehicle go down the hill or slope while stepping on the brake in order not to lose control.
- NEVER accelerate going down a hill or slope. Instead, lightly step the brake in order not to lose control.
- If vehicle will inevitably overturn, keep your body completely inside the vehicle. Press the floor firmly and grip tightly the steering wheel or copilot's handle.
- Do not attempt to stop the vehicle from overturning with any part of your body.

DRIVING TIPS

PAVED AREAS

- Try not to drive over paved surfaces as much as possible.
- Turn gradually and drive with caution if you need to drive on paved ways.
- Do not activate 4x4 or the differential in paved ways.

DRIVING THROUGH WATER

- Prevent from driving through water if possible.
- NEVER drive through fast-moving waters or waters deeper than 37 cm. This may cause losing control of the vehicle, being carried by the flow or even overturn.
- Before going into water first choose where to cross, avoid rocks or sudden descents. Always choose progressive descents.
- Pay particular attention and care when doing these operations.

REVERSE GEAR

- NEVER engage reverse if vehicle is not completely stopped. This causes a fast deterioration of the gearbox and could damage it.
- If manoeuvres in a little space are needed, make sure vehicle is completely stopped before shifting gears from forward to reverse and viceversa.
- NEVER force reverse, if it does not engage press lightly the accelerator and try again.

UNKNOWN TERRAINS

- If you do not know the terrain check it before driving in order to find hidden obstacles or elements that may be dangerous for your ride.
- Drive with caution and always use existing pathways.
- Drive with extra caution if visibility is poor.

DRIVING WITH LOAD

When driving **with load** in the cargo box or with a trailer:

- Reduce the speed and operate with LOW gear (L).
- Avoid hills or slopes.
- Load the cargo box correctly and drive with extra caution.
- A load with more than 450 kg may pose a risk for vehicle occupants. NEVER exceed that weight load in the cargo box.

• When you drive **towing any load**:

- Do not exceed 16 km/h when towing a heavy load with a short gear engaged.
- Do not drive aggressively when towing a load.
- Take into account that braking distance and vehicle stability will be affected by weight towed.
- Never park in slopes when a load is being towed.
- Avoid driving in unknown or difficult terrains. If needed, reduce the speed significantly and be aware of any danger that may be found.
- Always distribute weight between cargo box and trailer if possible. It will help improving vehicle stability.

CLEANING THE VEHICLE

To clean your CORVUS, perform the following steps:

1. Plug the exhaust system to prevent water from getting in.
2. Remove mud and dirt with a jet of water at low pressure.
3. Clean any especially dirty areas with a special cleaner or soap product.
DO NOT USE CORROSIVE PRODUCTS OR ACIDS.
4. Rinse with a jet of water at low pressure.
5. Let the vehicle drip dry naturally.
6. Unplug the exhaust pipe and drive around in the vehicle for a short distance until the engine reaches operating temperature, and apply the brakes.

This will let the water evaporate completely in the areas that are difficult to access.



Never use high-pressure equipment to clean the vehicle. Avoid aiming the jet of water directly at the multifunction panel, bearings, air cleaner, switches, controls or any other electrical element.

It is very detrimental to briefly start up the engine when the vehicle is stationary, because the engine is not hot enough and the air vapour created during combustion condenses and causes the oxidation of the exhaust valves.

VEHICLE STORAGE

When you have to store the vehicle for a long period of time you should:

- Clean the vehicle thoroughly and allow it to dry.
- Apply a wax-based corrosion inhibitor to the shiny or zinc-coated parts, except for the brake discs which are made of stainless steel and do not require any protection.
- Start the engine for about 5 minutes to warm the engine oil and then empty it (see maintenance).
- Change the filters and add new engine oil.
- Check the condition and the level of the antifreeze.
- Drain the fuel from the tank (if left for a long time, fuel deteriorates).
- Check the tire pressure and inflate them to their maximum pressure of 2 bars.
- Disconnect the battery.
- Cover the vehicle to protect it from dust and dirt.
- Store the vehicle in a dry place that is not subjected to important temperature changes.





To turn on the vehicle again, after storage:

- Connect the battery (having charged it previously).
- Replace the fuel filter.
- Fill the fuel tank.
- Check the points in the section “Daily inspection before driving”.
- Perform a brief test drive.



MAINTENANCE

SAFETY AND MAINTENANCE STANDARDS

-  - Were it to be necessary to keep the engine running to carry out a service on the vehicle, make sure that the work environment is well ventilated, and if necessary use adequate air extractors; **NEVER** run an engine in closed premises. The exhaust gases that are produced are toxic.
 - The battery electrolyte contains sulphuric acid. Protect your eyes, clothing and skin. Sulphuric acid is highly corrosive; in case of contact with eyes or skin, wash with plenty of water and go to a doctor immediately.
 - Batteries produce hydrogen, a gas that can be highly explosive. Do not smoke and avoid open flames or sparks near the battery, especially when you are charging it.
 - Fuel is extremely flammable and can explode under certain conditions. Do not smoke and do not allow any open flames or sparks in the work area.
 - Clean the brake pads in a ventilated place, directing the jet of compressed air in such a way that you do not breathe in the dust produced by the wear and tear of the friction material. Although such dust does not contain asbestos, inhalation is nevertheless harmful.
-  - Use original CORVUS spare parts and lubricants recommended by CORVUS. Non-original or non-compliant spare parts can damage the vehicle.
 - Only use tools designed specifically for this vehicle.
 - Always use new gaskets, sealing rings and pins during assembly.
 - After disassembly, clean the components with non-flammable solvent or one with a low flammability point. Lubricate all working surfaces before assembly, excluding the conical couplings.
 - After assembly, check that all components have been installed correctly and that they work perfectly.
 - For disassembly, inspection and assembly operations, only use tools with metric measurements. Metric screws, nuts and bolts are not interchangeable with connecting parts with English measurements. The use of unsuitable tools and connecting parts may damage your vehicle.

MAINTENANCE TABLE

The maintenance requirements set out in this table are simple and necessary for a good maintenance of your vehicle.

A: ADJUST / C: CHECK / L: LUBRICATE / R: REPLACE

ELEMENT		Daily	Interval						
			50 h	100 h	250 h	500 h	1000 h	1500 h	2000 h
Cooling	Check and refill coolant	C							
	Check and clean radiator fins			C					
	Check and adjust cooling belt		C (3)	C (4)					
	Drain, clean and refill system with new coolant					R (5)			
Cylinder	Adjust intake/exhaust valve settings					A			
	Secure intake/exhaust valves (if necessary)								A
Electrical	Check indicators	C							
	Check battery		C						
Engine Oil	Check engine oil level	C							
	Replace engine oil		R	R (4)					
	Replace engine oil filter		R	R (4)					
Emission control warranty	Inspect, clean and check fuel injectors (if necessary)							A	
	Inspect the crankcase breather system							A	
Fuel	Check and fill the fuel tank	C							
	Drain the fuel tank			C					
	Drain fuel filter water separator		C						
	Check fuel filter water separator	C							
	Clean fuel filter water separator					C			
	Replace fuel filter					R			
Hoses	Replace fuel system and cooling hoses								R (6)
Adm. and exhaust	Clean or replace air filter element			C	R				

(1) Perform more often if the vehicle is used intensively, in areas with a lot of dust, sand, snow, wet or muddy conditions. (2): Replace if necessary. (3): 1st time.

(4): (2nd time and thereafter). (5): or 1 years, whichever comes first. (6): or 2 years, whichever comes first.

MAINTENANCE TABLE

The maintenance requirements set out in this table are simple and necessary for a good maintenance of your vehicle.

A: ADJUST / C: CHECK / L: LUBRICATE / R: REPLACE

ELEMENT		Diario	Intervalo							
			50 h	100 h	250 h	500 h	1000 h	1500 h	2000 h	
Engine (complete)	General visual engine check	C								
CVT	CVT transmission belt (1) (2)		C (3)		C (4)					
	CVT pulleys				C					
	CVT air intake				C					
Transmission and differentials	Check gearshift and front/rear differential oil level				C					
	Replace gearshift and front/rear differential oil		R (3)		R (4)					
	Check transmission joint boots	C								
	Cardan gaskets	L								
Wheels and shock absorbers	Wheel bearings		C							
	Nuts and studs of the wheel bolts		C							
	Suspension ball joints and mounting points		C							
	Tire pressure and wear	C								
General check	Absence of leaks and state of seals (1)	C								R (6)
	Check brake fluid level	C								
	Replace brake fluid					R				
	Lubricate the wheel spindles, cardan gaskets and ball joints		L							
	Check and cleaning of underbody protectors	C								
	Status check of brake disks and pads	C								

(1) Perform more often if the vehicle is used intensively, in areas with a lot of dust, sand, snow, wet or muddy conditions. (2): Replace if necessary. (3): 1st time. (4): (2nd time and thereafter). (5): or 1 years, whichever comes first. (6): or 2 years, whichever comes first.

RAISING THE VEHICLE

The vehicle is equipped with an area at the front (1) and another at the rear (2) to facilitate its elevation.

! Before raising the vehicle, make sure the brake is fully on and that the surface is flat and completely horizontal.

! Do not perform any operation nor service while vehicle is being raised.
Do not touch or go in the vehicle until it is not completely raised and secured, it could unbalance it and make the vehicle overturn.

1. Place the base of the jack in the area indicated in the vehicle.

2. Raise the vehicle slowly, checking that it is stable.





UNDERBODY PROTECTOR

Removal:

1. Remove the 12 screws (1) from the front underbody protector.
2. Uncouple the protector.
3. Remove the 8 screws (2) from the rear underbody protector.
4. Uncouple the protector.

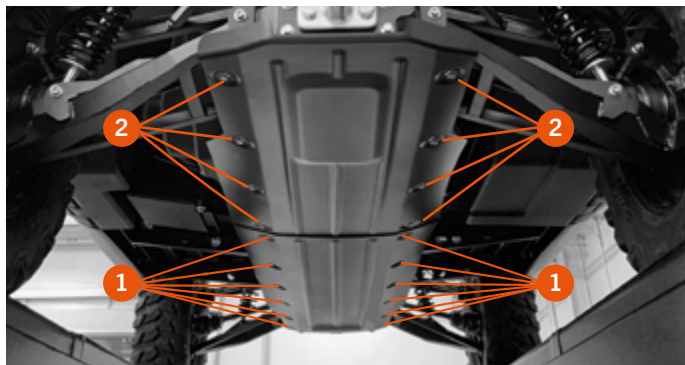
 Do not travel without underbody protectors, this could pose a risk on the integrity of the main components such as transmission.



 It is necessary to keep underbody protectors clean, both internally and externally. This will allow identifying vehicle's fluid loss, avoiding rusting due to standing water, etc.

WHEELS

Removal:

1. Put the vehicle in a horizontal position.
2. Engage the parking brake.
3. Raise the area of the vehicle (front or rear) where the wheel you are removing is located (p. 47)
4. Remove the four screws (1) holding the wheel rim.
5. Remove the wheel.

Perform the above process in reverse for the **installation**.

 **NEVER** travel with lack of any of the wheel screws, this would suppose a great risk for your safety.

 **TECHNICAL INFORMATION:** Wheel nut tightening torque: 70 Nm.

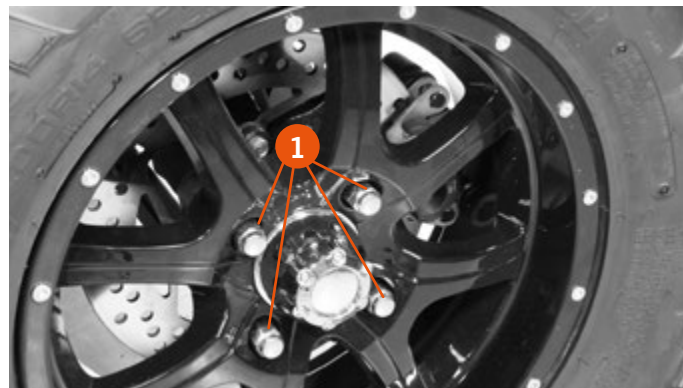

AIR CLEANING (CLEANING)

When cleaning the air cleaner, take care to make sure it does not become obstructed and that no dirt gets into the engine, especially when using the vehicle in dusty areas.

Without fail, inspect the air cleaner before and after each use, as indicated in the Maintenance Table.

Cleaning the air cleaner:

1. Release the latches (1) that hold the air cleaner cover.
2. Remove the air cleaner cartridge (2).
3. Clean with compressed air, from the inside toward the outside.

Recommendation:

Do not apply air at an excessive pressure, to avoid tearing the air cleaner paper which could result in severe engine damage.

Recommended air pressure between 42 - 71 PSI / 0.29 - 0.49 MPA / 3 - 5 KGF/cm²

 These operations must be carried out with the appropriate precaution, using a mask and goggles.

4. Clean the inside of the air cleaner housing (3), with a damp cloth.
5. Replace the air cleaner cartridge if it is very dirty, wet or deteriorated.

 A clogged air cleaner allows dirt into the engine, causing excessive wear and damaging it.

A clogged or damaged air cleaner can cause severe engine damage. Regulations oblige garages to collect and store, without mixing, hazardous or toxic waste, contaminated waste and inert non-hazardous waste. Such waste may not be dumped and must rather be processed by accredited managers.



TECHNICAL INFORMATION

Recommended air pressure between 42 - 71 PSI / 0.29 - 0.49 MPA / 3 - 5 KGF/cm²

Air cleaner cartridge: 02012260000

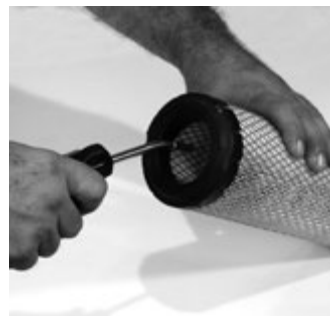
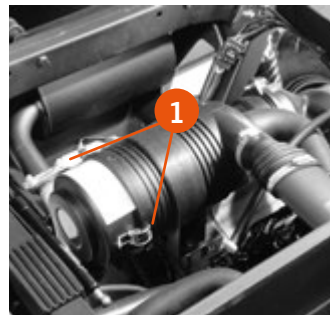

ENGINE OIL (LEVEL CHECK)

The smooth operation and durability of the transmission and the engine essentially depend on the oil being kept at the optimum level and being changed periodically, as indicated in the Maintenance Table (p. 44/45)

Checking the oil level:

1. Place the vehicle on a flat surface.
2. Run the engine so, that once the oil is warm it, can make any sediment rise up then turn it off after a few minutes.
3. Check the oil level using the cap/dipstick (1).
 - 3.1. Remove the cap/dipstick (1) and clean the dipstick with a clean cloth.
 - 3.2. Put it in again to smear it in oil.
 - 3.3. Remove the cap/dipstick (1) and observe the marked oil level.
 - 3.4. Put the cap/dipstick in again (1).
4. The oil level should be between the maximum and minimum marks (2) of the cap/dipstick.
5. **If the oil level is too high:**
 - 5.1. Place a container under the engine to collect the used oil and avoid any spillage.
 - 5.2. Remove the excess using the drain cap/screw (4).
 - 5.3. Tighten the cap/screw (4) replacing its washer.
6. **If the oil level is too low:**
 - 6.1. Fill it up with the required amount of oil, removing either of the two filler caps (3).
 - 6.2. Make sure to tighten these caps afterwards (3), maintaining their O-ring.
7. Run the engine for a few minutes.
8. Stop the engine and after about 5 minutes, check the oil level again.

 When filling the tank by adding new oil, you must use the same type of oil already in the engine.

Perform several checks during refilling, avoiding exceeding the maximum level.



TECHNICAL INFORMATION:

Recommended oil: SAE 15W40 - API CD, CF, CF-4 y CI-4 / ACEA E-5.
Capacity: 1.7 L. Tighten the drain cap/screw to 58 Nm .

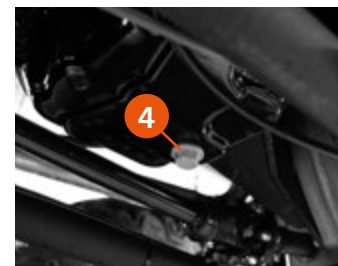
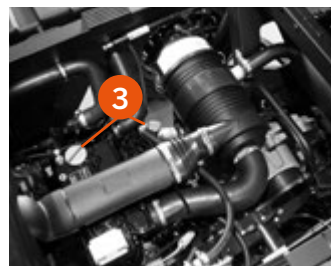
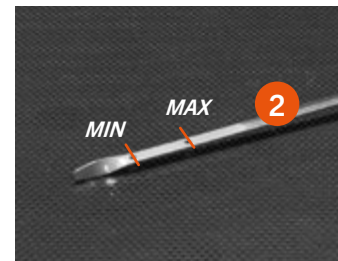

ENGINE OIL (CHANGE AND FILTER)

You should keep the oil at the optimum level and change it periodically, as indicated in the Maintenance Table (p. 44/45).

Oil and oil filter change:

1. Place the vehicle on a flat surface.
2. Run the engine so that once the oil is warm it can make any sediment rise up. Then turn it off after a few minutes.
3. Place a container under the engine to collect the used oil and avoid any spillage.
4. Remove the cap/dipstick level (1) and the two filler caps (2), to make it easier to drain the oil.
5. Remove the drain cap/screw (3) and wait until all the content has emptied out.
6. Remove the filter (4) and discard.
7. Put the new filter in place, lubricate the O-ring seal (5) and tighten manually, without using any tools.
8. Tighten the cap/screw (3) replacing its washer.
9. Fill with new oil.
10. Ensure the tightness of the cap/dipstick level (1) and the filler caps (2), with their O-ring.
11. Run the engine for a few minutes.
12. Stop the engine and after about 5 minutes, check the oil level again, as per the instructions given for the oil level check.

TECHNICAL INFORMATION: Recommended oil: SAE 15W40 - API CD, CF, CF-4 y CI-4 / ACEA E-5. Capacity: 1.7 L.
Tighten the drain cap/screw to 58 Nm.
The air cleaner cartridge: 02990000052

! To ensure the smooth operation of the transmission and the engine keep the oil at the optimum level and change it periodically, as indicated in the Maintenance Table (p. 44/45).

Insufficient, degraded or contaminated oil can accelerate the wear and tear of a vehicle and cause serious engine damage. Regulations oblige garages to collect and store, without mixing, hazardous or toxic waste, contaminated waste and inert non-hazardous waste. Such waste may not be dumped and must rather be processed by accredited managers.

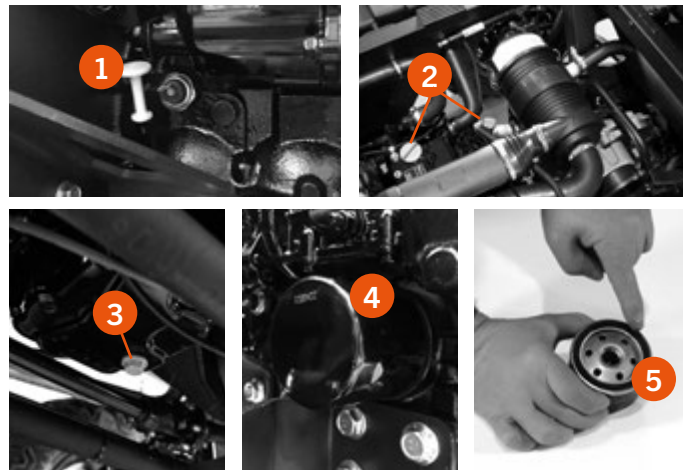

WATER PRE-FILTER

Water pre-filter (1) is placed below cargo box, so in order to have access it is necessary to raise the cargo box.

Regularly check pre-filter. Replace the pre- filter in your CORVUS service if it is worn, if it has lost efficiency or if usage hours in the maintenance table have been exceeded.

! A worn pre-filter may accelerate engine wear and end up breaking it. **NEVER** start the engine without the pre-filter.

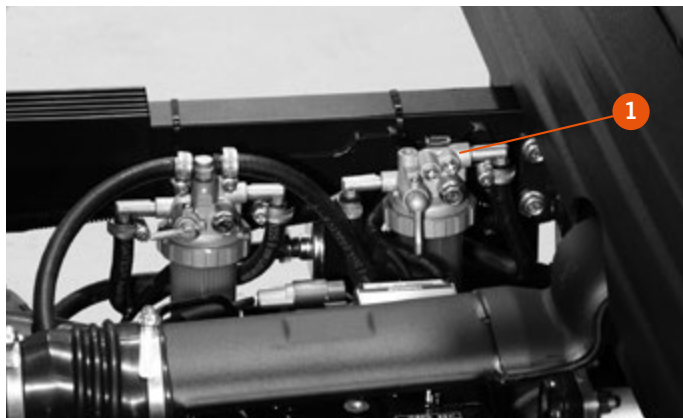

FUEL FILTER

Fuel filter (2) is placed under cargo box, so in order to have access it is necessary to raise the cargo box.

Regularly check the filter. Replace the filter in your CORVUS service if it is worn, if it has lost efficiency or if usage hours in the maintenance table have been exceeded.

! A worn filter may accelerate engine wear and end up breaking it. **NEVER** start the engine without fuel filter.

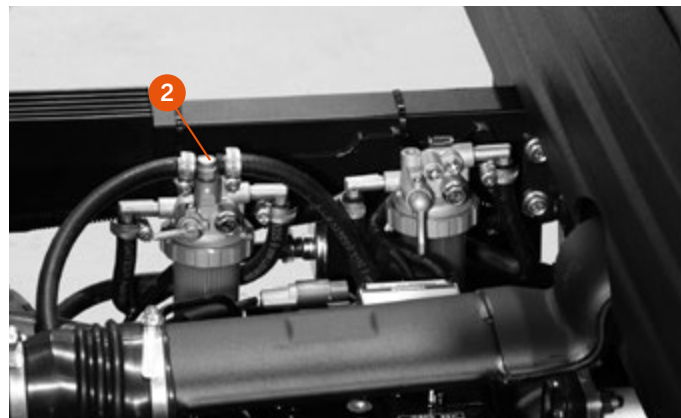

TRANSMISSION OIL (LEVEL CHECK)

The smooth operation and durability of the transmission essentially depend on the oil being kept at the optimum level and being changed periodically, as indicated in the Maintenance Table (p. 44/45).

Checking the oil level:

1. Put the vehicle in a horizontal position.
2. Run the engine for a few minutes and turn it off.
3. Remove the level screw (1).
4. If a slight amount of oil oozes from the hole, the level will be correct. If, on the contrary, no liquid oozes from the hole, you should continue to add more oil.
5. If you need to add more oil, you must do so through the filler cap (2).

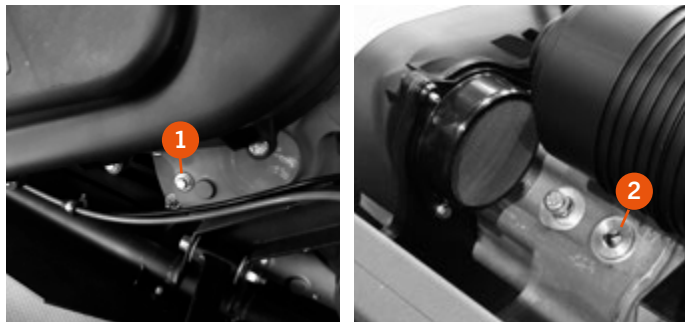

TRANSMISSION OIL (CHANGE)

Changing the transmission oil:

1. Put the vehicle in horizontal position and lift the load box.
2. Remove the rear protector (p. 47).
3. Place a container under the transmission to collect the used oil and avoid any spillage.
4. Remove the filler plug (1), to facilitate a better drainage of the transmission oil.
5. Remove the transmission oil drain screw (2).
6. Once all the oil has drained from the transmission, replace the washer and make sure the drain screw is tightened to 24 Nm.
7. Fill the transmission with new oil.
8. Attach the filler cap (2).

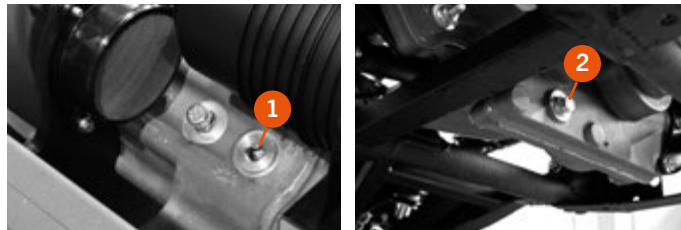

TECHNICAL INFORMATION:

Recommended oil: SAE 80W-90, API GL5.
Capacity: 1,7 L.



NEVER drive the vehicle with no oil in the gearbox or with low oil level. It is important to be aware of maintenance periods of the components shown in the maintenance table.

FRONT DIFFERENTIAL OIL (CHANGE)

CHECK:

To check the front differential oil level, you have to drain the oil into a calibrated container and measure the amount that has been extracted. The correct volume is 0.5 L.

CHANGE:

The oil must be changed periodically, to ensure the life of the differential, as indicated in the Service Chart (p. 44/45).

1. Park the vehicle in a totally horizontal position.
2. Remove the battery.
3. Remove the front underbody protector before starting the operation (p.47).
4. Place a container under the differential to collect the used oil and avoid any spillage.
5. Remove the filler plug/screw (1), to facilitate better oil drainage.
6. Remove the drain plug/screw (2) and wait until all the content has drained out.
7. Screw on the drain plug/screw (2) and tighten the drain plug, replacing the washer, securing it at 24 Nm.
8. Fill the front differential with the new oil.
9. Screw on and make sure the corresponding filler plug/screw (1) is tight, replacing its washer, securing it at 24 Nm.
10. Check that there are no leaks and that the seals are in good condition.



TECHNICAL INFORMATION:

Recommended oil: SAE 80W-90, API GL5.
Capacity: 0,5 L.



NEVER drive the vehicle with no oil in the front differential or with a low oil level.

It is important to be aware of maintenance periods of the components shown in the maintenance table.

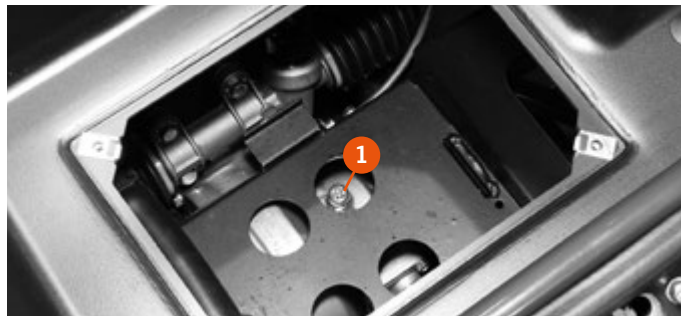

4X4 LOCKING SYSTEM OIL

CHECK:

To check the 4X4 locking system oil level, you have to drain the oil into a calibrated container and measure the amount that has been extracted. The correct volume is 0.05 L.

CHANGE:

It is convenient to frequently check that there are no leaks and the maintenance of the oil level, for correct operation.

Changing the locking system oil.

1. Put the vehicle in the horizontal position and remove the front underbody protector (p. 47).
2. Place a container under the 4x4 locking system to collect the used oil and avoid any spillage.
3. Remove the filler plug (1), to facilitate a better drainage of the 4x4 oil.
4. Remove the drain screw (2) the 4x4 locking system oil.
5. Once all the oil has drained out, replace the washer and make sure the drain screw is tightened at 24 Nm.
6. Fill with 0.05 L of new oil.
7. Replace the plug washer and tighten the oil filler plug (1) at 24 Nm.



TECHNICAL INFORMATION:

Recommended oil: SAE 80W-90, API GL5

Capacity: 0.05 L

Tighten the filler plug/screw to 24 Nm.

Tighten the drain plug/screw to 24 Nm.



NEVER drive the vehicle with no oil in the 4X4 locking system or with a low oil level.

It is important to be aware of the maintenance periods of the components shown in the maintenance table.

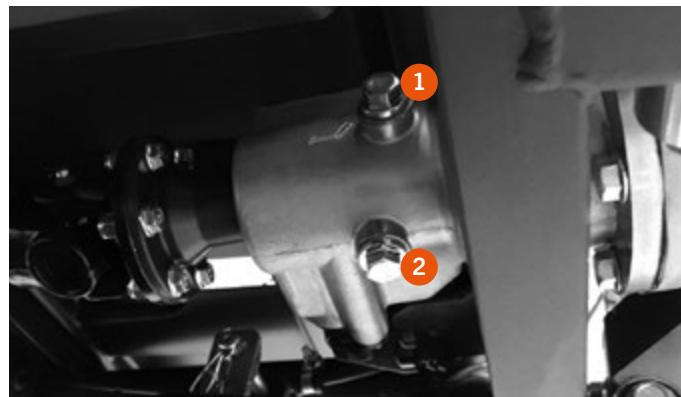

FRONT HOOD BASE

REMOVAL:

Previously, you need to remove the front hood.

1. Loosen the 11 screws (1) holding the hood base and remove it.
2. Remove the hood safety lock (2).
3. Remove the cylinder from the lock (3).



TECHNICAL INFORMATION

Lock screws tightening torque: 12 Nm

Locking screws tightening torque: 12 Nm



NEVER drive the vehicle with the front trunk base removed.

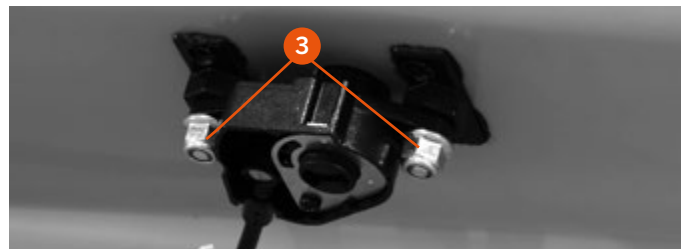
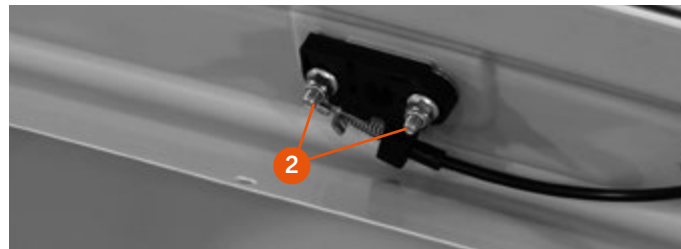
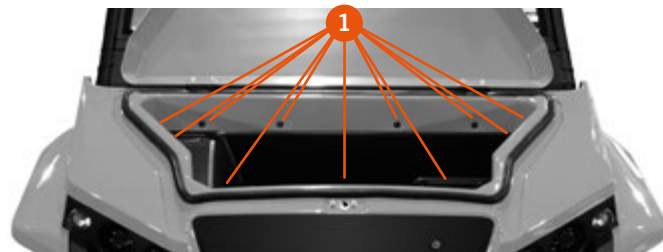

LIGHTS

ADJUSTING THE HEIGHT

1. Position the vehicle 10 meters from a wall and use the parking brake to immobilize it.
2. Open the front hood.
3. Unscrew the eleven screws from the base of the hood and remove it.
4. Use the screws to adjust the headlights (1).
5. The light beam must be 30 cm below the horizontal line projected onto the wall from the centre of the lamp.



Bulbs and headlights can be very hot.

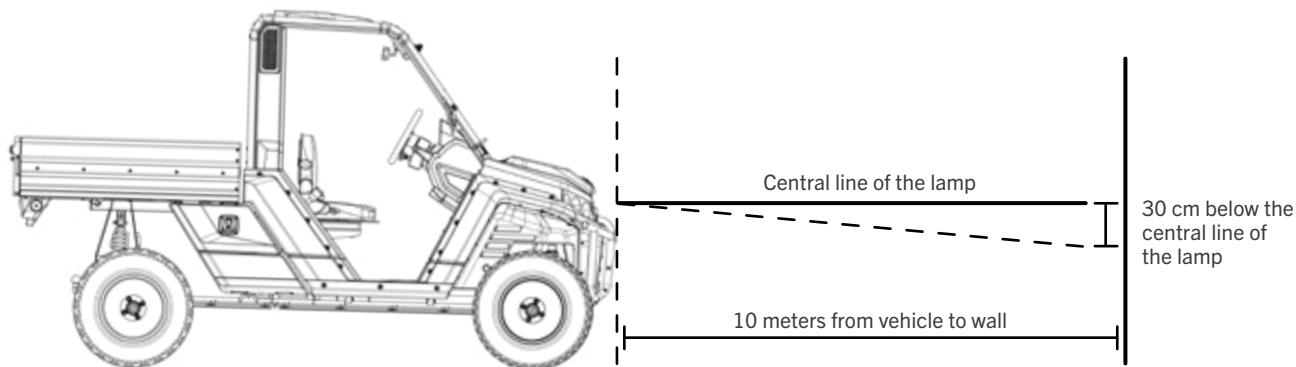
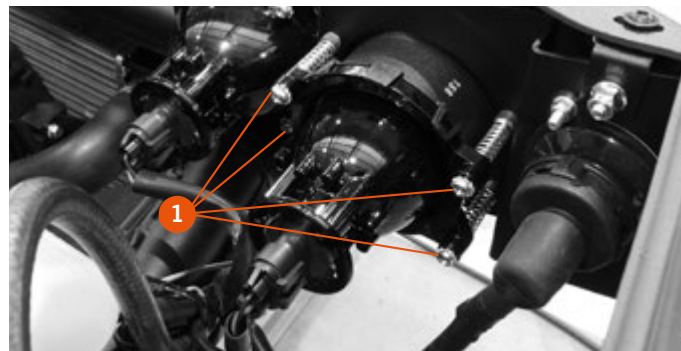

FRONT LOW AND HIGH BEAM LIGHTS AND INDICATORS



Bulbs and headlights can be very hot.

Replacement:

1. Switch the vehicle off.
2. Open the front hood.
3. Remove the base of the hood (p. 55)

Replacing the low / high beam lamps:

1. Unplug the electrical connector (1) of the lamp you are replacing.
2. Turn the bulb counterclockwise to remove it from its housing.



TECHNICAL INFORMATION:

Low and high beam headlamps: HB3 12V 60W,
Ref. 09180040003.

Replacing the indicator lamps:

1. To replace the indicator lamps, turn the bulb holder bushing (2) counterclockwise to disconnect it from its housing.
2. Turn the lamp and separate it from the bushing.



TECHNICAL INFORMATION:

Indicators lamp: 12V 21W,
Ref. 08000960000



Do not drive the vehicle without lights or indicator lamps, they represent an important safety measure.



REAR INDICATOR, BRAKE AND SIDELIGHT LAMPS



Bulbs and pilot cap could be very hot.

Replacement:

1. To access the rear lamps, you will have to remove the light cover that is anchored with the two screws indicated in the image (1).

2. You will then be able to see the two lamps:

- Indicator (2)
- Brake and sidelight (3)



TECHNICAL INFORMATION

Indicator lamp: 12V, 21W, Ref. 09180040001

Brake and sidelight lamp: 12V, 21W/5W, Ref. 09180040002



Do not drive the vehicle without brake lights, indicators, or sidelights as they are important safety elements

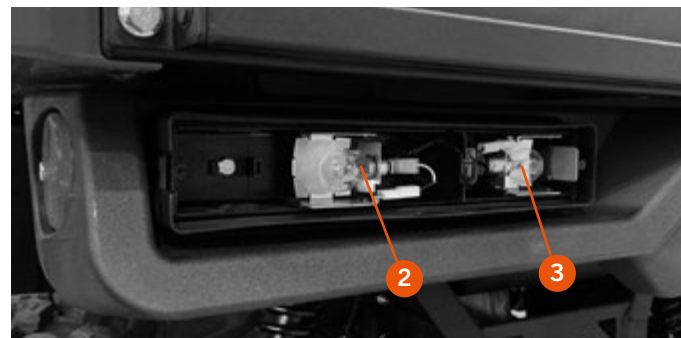
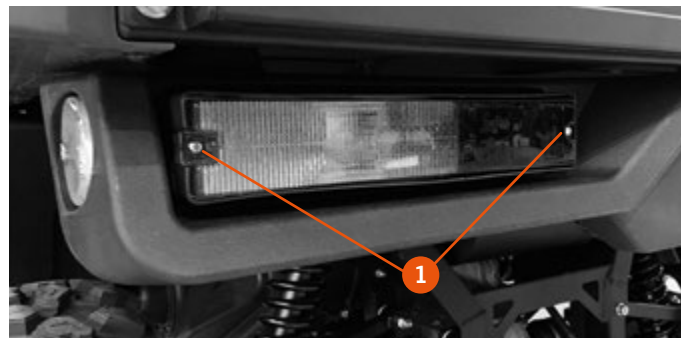

LIQUID COOLANT

The coolant absorbs excess heat from the engine and transfers it to the air through the radiator. If the fluid level decreases, the engine overheats and can be severely damaged.

Check the fluid level every day before driving your CORVUS.

To protect the aluminium parts within the cooling system (the engine and the radiator) from oxidation and corrosion, use chemical inhibitors in the coolant. If you do not use an anti-corrosive liquid, the radiator will begin to rust after a while. This would obstruct the cooling pipes.

NOTE: Initially, the factory uses permanent-type antifreeze. It contains 50% ethylene glycol and has a freezing point of -35°C .

 Liquid chemicals are harmful to the human body. Follow the manufacturer's instructions.

 The use of incorrect liquid solutions may cause damage to the engine and the cooling system. Use coolant with a specific corrosion inhibitor for aluminium engines and radiators in accordance with the manufacturer's instructions. If coolant level is correct and the vehicle temperature keeps increasing, even if its turned on for a few minutes, it can be due to the presence of bubbles in the circuit and must be purged. If high temperature still persists contact CORVUS service.

 To avoid burns do not remove the radiator cap or try to change the fluid when the engine is still hot. Wait until it cools down.

Coolant level:

1. Place the vehicle on a flat surface.
2. Unscrew the cap from the reservoir (1) in an anticlockwise direction and wait a few seconds until the vapours disperse.
3. Check the coolant level. The liquid must not exceed the line marked (MAX).
4. If the fluid level is low, add the required amount through the filling aperture.

Recommended fluid: 50% Long time. (-35°C).

 If liquid falls onto the tires, it makes them more slippery and can cause an accident. Immediately clean any liquid that may fall on the chassis, engine or wheels. Inspect any old liquid. If you notice white patches in the liquid, it means that the aluminium parts of the cooling system are corroded. If the liquid is brown it means that the steel or iron parts of the system are oxidised. In both cases, clean the system.

 Replace the gaskets with new ones. Check for any potential damage, leaks or lack of gaskets in the cooling system. In countries with cold weather you should adjust the antifreeze capacity to your minimum temperature, adding a margin of -5°C .



RADIATOR HOSEPIPE AND CONNECTIONS

Radiator hosepipes:

Check that the radiator hosepipes do not have cuts or are damaged and that the connections do not have leaks.

Radiator:

Check that the radiator fins are not obstructed (insects or mud). Clean any such obstructions with a jet of water at low pressure.



Using high pressure water can damage the radiator fins and diminish the effectiveness. Do not obstruct or divert the air inlet to the radiator by installing any unauthorized accessories. Interfering with the radiator may cause it to overheat and damage the engine.

Replace the radiator if it is damaged or has lost efficiency.



HAND BRAKE CABLE

To adjust the tension of the handbrake cable, follow this procedure:

1. Loosen the nut (1).
2. Adjust the angle between the cam and the handbrake cable. To do this, turn the shaft (2) with a flat screwdriver. In this way, when the handbrake is applied, this angle is 85°.
3. Fasten the nut (1).
4. Follow this process for the two brake callipers.



TECHNICAL INFORMATION

The cam must be adjusted in such a way that when the parking brake is applied to its maximum extent, the angle of the cam with reference to the cable has to be $85^\circ \pm 0.5$.



Don't execute this operation with the handbrake on. Only activate it when the nut (1) is fastened.

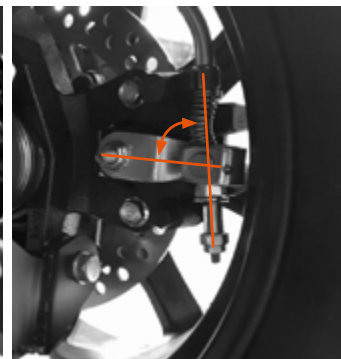
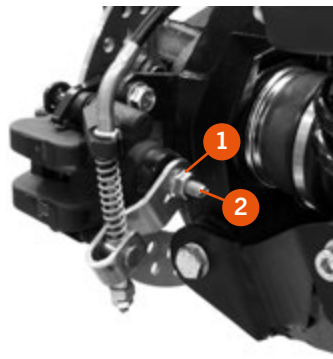

BRAKE WEAR

If the thickness of any of the front or rear disc brake pads is less than 1.5 mm, completely change the set of affected pads.

 Check that the thickness of the front and Rear discs is at least 3.5 mm.

 We recommend that you go to your CORVUS dealer to change the brake pads. They will also check for any possible wear of the brake discs.

BRAKE FLUID

Inspect the brake fluid and change it regularly. You must also change it if is contaminated by water or dirt.
Recommended fluid: DOT-4 brake fluid.

 Do not mix different types of brake fluid. The fluid used to fill or renew your circuit must correspond to the specified standard in the fluid reservoir of each circuit. You should never change the specification, always respect the dot-4 specification. What is important is not that the brake fluid should be the same brand, rather that it must have the same specification. Never use fluid from a container that is not sealed (unopened) at source. Never use brake fluid that has already been used.

The brake fluid level must be within the indicated MIN / MAX range (1). If there is not enough liquid, it should be added.

 Do not spill brake fluid on paintwork.

 Check that there is no loss of liquid through the gaskets. Check for possible damage to the brake sleeves.

It is recommended that you replace the brake fluid every 2 years.

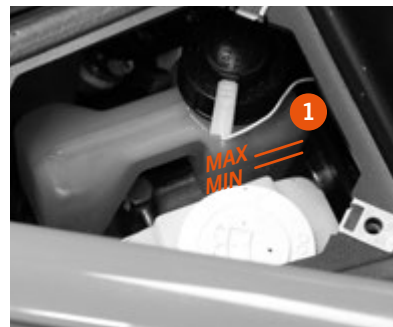

TIRES

Check that the tires are not worn, cracked or damaged. Also check that they are at the correct pressure.

Recommended front/rear pressure:

1.0 bar (empty vehicle)

1.5 bar (vehicle at full load)



BOLTS, NUTS AND FASTENINGS

Every day before you drive your vehicle you should check that all the nuts and bolts are tight.

You should also check that the other fastenings are in place and in good condition.



NEVER drive with lack of nuts or screws, this could cause an accident or serious damage.

BATTERY

The battery (12 V and 55 Ah) does not need maintenance.

The vehicle counts on 3 free auxiliar connectors with a maximum individual charge capacity of 150W to 12V. Never exceed that capacity, it could avoid having problems in the electric system or the battery..

These connectors are placed:

- Behind central bottom panel of the dashboard (positive direct to battery).
- Behind the roof upper bottom panel (positive after contact).
- Left rear part of the vehicle (positive after contact).

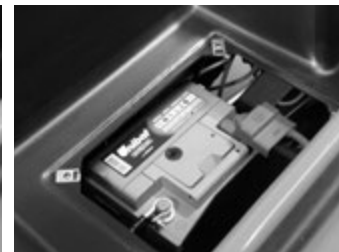
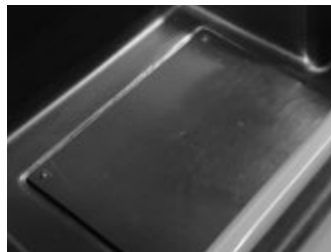

BATTERY

Changing the battery

The battery is located under the front hood, inside the battery box.

To change it, perform the following steps:

1. Loosen the 4 screws of the battery cover and remove it.
2. Loosen the mounting bolt from the battery claw and remove it.
3. Loosen the battery terminals and remove it.

Replace the battery with a new one and follow the steps in reverse order to reassemble it.



Do not handle or try to open the battery, the electrolyte and gases are toxic and can cause serious injury.

Keep the battery out of the reach of children.

Keep the battery away from sources of heat, open flames and sparks.

Always store and charge the battery in well-ventilated areas.

Use protective clothing and goggles.

LIGHTING AND PILOT LIGHTS

The headlamps and the turn signal lamps are located on the **front** of the vehicle.

1. The low beam headlamps (short) have a screw in their interior so you can adjust their height.
2. The long beam headlamps have screws in their interior so you can adjust their height.
3. Front turn signal lamps.



The brake lights / position headlamps, the turn signal lamps and the reflectors are located on the **rear** of the vehicle.

4. Reflectors
5. Rear brake and position lights.
6. Rear turn signal lamps.
7. Your vehicle also has a number plate light.

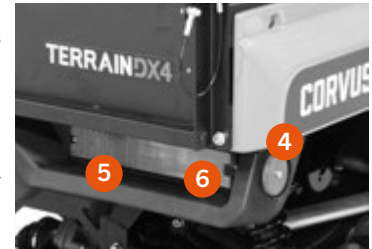

Pilot lights' surface can be very hot.



NEVER drive the vehicle without lights or indicator lamps. These represent an important safety measure.



WINDSCREEN

WINDSHIELD WIPER BLADE *

To remove the wiper blade:

- 1 - Separate the windshield wiper arm.
The arm and the wiper blade must form an angle of 90°.
- 2 - Press the central clip.
- 3 - Remove the racket downwards.

To assemble the wiper blade:

- 1 - Place the windshield wiper arm between the wiper blade.
- 2 - Place the tip of the arm onto the central clip.
- 3 - Twist the wiper blade and return the arm to its initial position.



WINDSCREEN CLEANER

The windscreen wiper fluid reservoir is located under the front hood.

- 1 - Place the vehicle on a flat surface.
- 2 - Remove the four screws from the cap.
- 3 - Remove the cap.
- 4 - Fill the tank with fluid up to the top.
- 5 - Screw the cap back on.
- 6 - Check it works properly.



FUSES

LOT 1

To access the fuse box you will need to remove the 2 screws on the cover located to the left of the driver's seat.

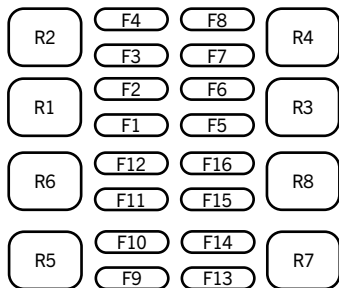
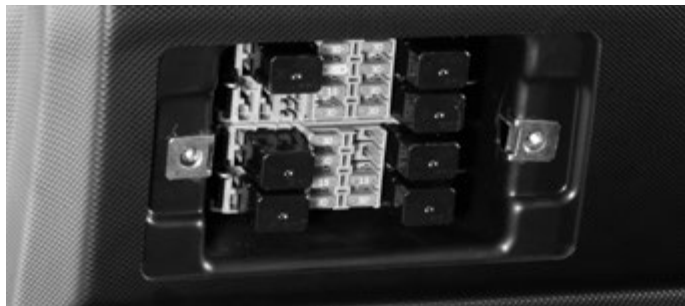

Element

30A	F1 - Glow plug
15A	F2 - AUX supply
30A	F3 - Radiator fan
25A	F4 - Key / Low beam / Horn
25A	F5 - Starter relay
25A	F6 - Fuel pump / High beam / Windshield wipers
30A	F7 - Power Steering
30A	F8 - Engine power control
25A	F9 - Heating / AC
15A	F10 - Trailer power supply
30A	F11 - Solenoid
30A	F12 - Engine power control
15A	F13 - 4WD / Differential lock
15A	F14 - 12V Accessory socket

R2 - Heaters
R3 - Safety start-up
R4 - Radiator fan
R5 - F9 and F10 supply
R6 - F11 and F12 supply
R7 - F13 and F14 supply
R8 - General supply

! NEVER use different fuses from the indicated. That could lead to a wrong functioning or failure of the electric system.

FUSES

LOT 2

To access the fuse box you will need to remove the 2 screws on the cover located to the left of the driver's seat.

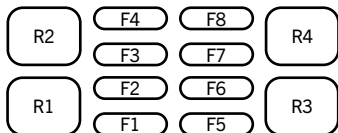
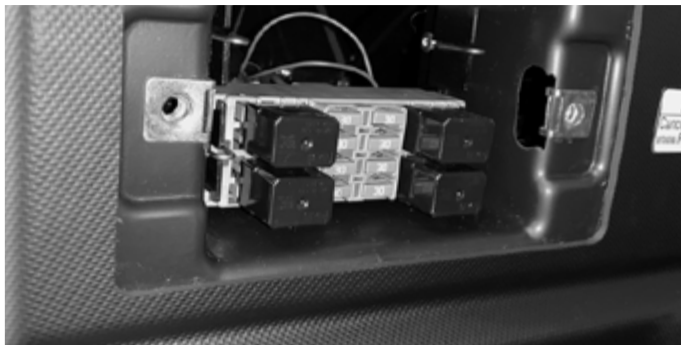

Element

30A	F1 - Glow Plug
30A	F2 - EPS System
30A	F3 - Radiator fan / Horn / Beacon light Warning switch / Engine power control
25A	F4 - Key switch / Low beam
25A	F5 - Starter relay / AUX supply
30A	F6 - Heating / 12V Accessory socket
25A	F7 - Fuel pump / Stop solenoid / Differential lock / Trailer connection / Rear lights
30A	F8 - Safety relay / High beam / Wipers / 4WD
	R1 - Safety start-up
	R2 - Radiator fan
	R3 - F6 supply
	R4 - F7 and F8 supply

LUBRICATION

Your vehicle is equipped with grease nipples to facilitate the lubrication of certain parts (2 in each rear wheel spindle, 2 in each cardan joint and 1 in the transmission cardan/output coupling joint).

- 1- Cardan-Transmission hub grease nipple.
- 2- Transmission coupling grease nipple.
- 3- Transmission coupling grease nipple.
- 4- Lower rear wheel spindle grease nipple.
- 5- Upper rear wheel spindle grease nipple.

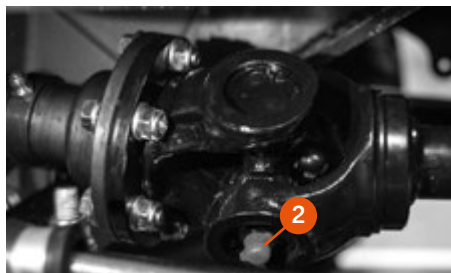
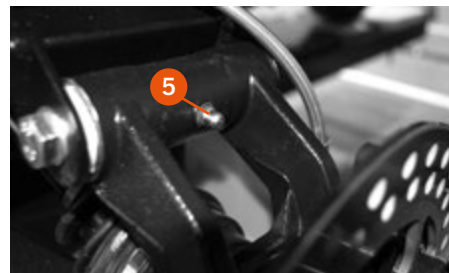
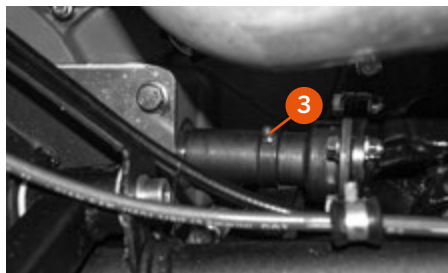



PRODUCT LIABILITY

PRODUCT LIABILITY

SUPPLEMENT SUBJECT TO PRODUCT LIABILITY DIRECTIVE 1999/34/CE OF 10/05/1999

1. The User Manual has been delivered to the customer or to his or her legal representative when they have taken delivery of the product. A contact person has been appointed to respond to queries.
2. The product has been presented to the client (legal representative) before it was handed over. The client (legal representative) has been informed that the product should be used only in accordance with the conditions laid down by the manufacturer (as described in the User Manual). The client (legal representative) fully understands the instructions.
3. The client (legal representative) has been informed that the manufacturer shall not be liable for problems resulting from any modification of the vehicle.
4. The client (legal representative) declares by their signature that they have been informed and that they understand the points set out above.

Date and signature of the client (legal representative).



WARRANTY MANUAL

PRELIMINARY WARNINGS

(According to Royal Legislative Decree 1/2007, of 16 November, approving the revised text of the General Law for the Defence of Consumers and Users and other complementary laws.)

Regulatory standards of the warranty of the manufacturer **CORVUS INNOVA S.L.** Hereinafter, “**CORVUS**”.

The company **CORVUS**, hereby warrants to the end consumer, the purchaser of a vehicle manufactured by **CORVUS**, that both the materials and the manufacture are free from defects in accordance with the highest quality standards.

Consequently, **CORVUS** hereby guarantees to the end purchaser (hereinafter, the “buyer”), in accordance with the conditions expressed below, the repair of any material defect, hidden defect or manufacturing defect detected in a new vehicle, without charge, within the given warranty period and with 1000 operating hours.

WARRANTY PERIOD

The warranty period shall begin on the date the vehicle is delivered to the buyer by an authorized **CORVUS** dealer or official distributor, or in the case of demonstration models, on the date on which the vehicle begins operating for the first time. The seller shall be liable for any lack of conformity which might become manifest within the deadline set out in Royal Legislative Decree 1/2007, of 16 November, approving the revised text of the General Law for the Protection of Consumers and Users from the time of delivery and in accordance with Directive 1999/44/EC for the rest of the Member States of the European Community. For countries outside the European Community, the warranty term shall be governed by the rules in force therein. However, if the lack of conformity becomes apparent during the first six months from delivery of the vehicle, it is presumed that such failure already existed when it was handed over; from the sixth month, the buyer shall have to demonstrate that the lack of conformity existed at the time of delivery of the asset. During the first six months after delivery of the repaired goods, the seller shall respond to the non-conformity led to the repair.

Any defect found in the product will have to be brought to the attention of an official **CORVUS** distributor or authorized dealer within the warranty period. If the last day of the warranty period falls on a Sunday or an official holiday, the warranty period will be extended in such a way that the last day of the warranty period is the first working day after the Sunday or the official holiday.

Warranty claims for defects not be brought to the attention of an official **CORVUS** distributor or authorized dealer before the end of the warranty period will be excluded.

OBLIGATIONS OF THE BUYER

CORVUS shall be entitled to refuse warranty claims if and to the extent that:

1. The buyer has not proceeded to submit to the vehicle to any of the inspections and/or maintenance work required in the user's manual or has exceeded the date laid down for such inspections or maintenance work, also excluding from the warranty such defects as may appear prior to the date set for an inspection or maintenance work that was never carried out, or was carried out after the established date.

PRELIMINARY WARNINGS

2. If inspection, maintenance or repair work has been carried out by third parties not recognized or authorized by **CORVUS**.
3. Any maintenance or repair work that has been carried out in violation of the technical requirements, specifications and instructions provided by the manufacturer.
4. Spare parts not authorized for use by **CORVUS** have been used when carrying out maintenance or repair work on the vehicle, or if and to the extent that it the vehicle has been used while using fossil fuels, lubricants or other liquids (including, among others, cleaning agents) that have not been expressly mentioned in the specifications of the User Manual.
5. The vehicle has been in any way altered or modified or equipped with components other than those that have been expressly authorized by **CORVUS** as admitted vehicle components.
6. The vehicle has been stored or transported in a manner not consistent with the technical requirements.
7. The vehicle has been used for a special use different from ordinary use, such as a competition, racing or an attempt to obtain whatsoever record.
8. The vehicle has been involved in an accident that has directly or indirectly caused damage.

WARRANTY EXCLUSIONS

The following items will be excluded from the warranty:

1. Worn parts, including, without limitation, batteries, fuel filters, the oil filter element, air cleaners, brake discs, brake pads, clutch plates, CVT belts, CVT rollers, CVT variator, light bulbs, fuses, carbon brushes, tires, cables and other rubber components, and in general any parts subject to wear and tear.
2. Lubricants (for example, oil, grease, etc.) and operating fluids (for example, battery fluid, coolant, etc.).
3. Inspection, adjustment and other maintenance work, as well as all types of cleaning work.
4. Paint damage and subsequent corrosion due to external influences, such as stones, salt, industrial exhaust gases and other environmental impacts or improper cleaning using unsuitable products.
5. Damage caused by defects, as well as expenses caused directly or indirectly by defects (for example, communications costs, accommodation expenses, rental car expenses, public transportation expenses, crane expenses, urgent courier costs, etc.), as well as other financial damages (e.g., caused by the loss of use of a vehicle, loss of revenue, loss of time, etc.).
6. An acoustic or aesthetic phenomenon that does not significantly affect the nature of the use of the vehicle (for example, small or hidden imperfections, noise or vibrations due to normal use, etc.).
7. Phenomena due to the ageing of the vehicle (for example, the discolouring of paintwork or metalwork).

PRELIMINARY WARNINGS

VARIOUS

A. Were the repair of the defect or the replacement of the part to be disproportionate, **CORVUS** will have the prerogative to decide at its sole discretion whether to repair or replace defective parts. Ownership of the replacement parts or the replaced parts, as the case may be, shall correspond to **CORVUS** without any other consideration. The official **CORVUS** distributor or authorized dealer to whom the repair of such defects has been entrusted will not be authorized to make binding declarations on behalf of **CORVUS**.

B. In the case of doubt as to the existence of a defect or if a visual or material inspection is required, **CORVUS** reserves the right to demand the return of parts covered by a warranty claim or to request a review of the defect by a **CORVUS** expert. Any additional warranty obligations on parts replaced without charge or for any service provided free of charge under this warranty will be excluded. The warranty for spare parts within the warranty term will end on the date of expiry of the warranty term of the product concerned.

C. If it were to prove impossible to repair a defect and the replacement thereof were to be disproportionate for the manufacturer, the consumer is guaranteed the right to cancel the contract (payment of compensation) or to a partial refund of the purchase price (discount), instead of the repair of the vehicle.

D. Warranty claims made by the buyer under the sale and purchase agreement entered into with the corresponding official distributor or authorized dealer will not be affected by this warranty. This warranty will not affect the additional contractual rights of the buyer under the general conditions of business of the authorized dealer. Such additional rights, however, can only be claimed from the official distributor or authorized dealer.

E. If the buyer were to resell the product within the warranty period, the terms and conditions of this warranty will continue to exist with the current scope, so that the rights to file a claim under this warranty in accordance with the terms and conditions covered by this document will be transferred to the new owner of the vehicle.

CHANGE OF OWNER

OWNER No. 2

NAME AND SURNAME:

ADDRESS:

POST CODE / TOWN:

PHONE:

MOV.:

E-MAIL:

I confirm that I have received Proof of Delivery, the User Manual and two sets of keys. I have completely read and I understand the User Manual. I know the maintenance intervals. I know the warranty conditions.

Date and signature of the client (legal representative).

For your own safety (e.g. for the possible withdrawal campaigns by the manufacturer), we recommend, as a new owner, that you inform an official **CORVUS** distributor or authorized dealer, or **CORVUS**, itself directly, that you have purchased a **CORVUS** vehicle, so that your data can be registered in the service. This will ensure that you are correctly made aware of any campaign that might affect you.

CHANGE OF OWNER

OWNER No. 3

NAME AND SURNAME:

ADDRESS:

POST CODE / TOWN:

PHONE:

MOV.:

E-MAIL:

I confirm that I have received Proof of Delivery, the User Manual and two sets of keys. I have completely read and I understand the User Manual. I know the maintenance intervals. I know the warranty conditions.

Date and signature of the client (legal representative).

For your own safety (e.g. for the possible withdrawal campaigns by the manufacturer), we recommend, as a new owner, that you inform an official **CORVUS** distributor or authorized dealer, or **CORVUS**, itself directly, that you have purchased a **CORVUS** vehicle, so that your data can be registered in the service. This will ensure that you are correctly made aware of any campaign that might affect you.



MAINTENANCE LOG

MAINTENANCE LOG

Date: _____ Km: _____

Next service: _____

Notes: _____

Stamp: _____

Date: _____ Km: _____

Next service: _____

Notes: _____

Stamp: _____

Date: _____ Km: _____

Next service: _____

Notes: _____

Stamp: _____

Date: _____ Km: _____

Next service: _____

Notes: _____

Stamp: _____

MAINTENANCE LOG

Date: _____ Km: _____

Next service: _____

Notes: _____

Stamp: _____

Date: _____ Km: _____

Next service: _____

Notes: _____

Stamp: _____

Date: _____ Km: _____

Next service: _____

Notes: _____

Stamp: _____

Date: _____ Km: _____

Next service: _____

Notes: _____

Stamp: _____

NOTES

We reserve the right to modify the product and the design.



CORVUS-UTV.COM